

SURFACES & SUPPORTS

Ultra Surfaces, Std. Laminate, Square Edge	4.2
Ultra Surfaces, ESD Laminate, Square Edge	4.3
Ultra Surfaces, Chemsurf Lam., Square Edge	4.5
Ultra Surfaces, Hardwood, 1¼", Full-Radius Edge	4.6
Ultra Surfaces, Hardwood, 1¾", Square Edge	4.7
Ultra Surfaces, Stainless Steel	4.8
Phenolic Systems Surfaces	4.9
Corian Systems Surfaces	4.10
Std. Surfaces, Std. Laminate, Square Edge	4.11
Std. Surfaces, ESD Laminate, Square Edge	4.12
Std. Surfaces, Chemsurf Lam., Square Edge	4.14
Work Surfaces, Standard Laminate, T-Edge	4.15
Work Surfaces, Std. Laminate, Square Edge	4.16
Work Surfaces, ESD Laminate, T-Edge	4.17
Work Surfaces, ESD Laminate, Square Edge	4.18
Work Surfaces, Chemsurf Laminate, T-Edge	4.19
Work Surfaces, Chemsurf Lam., Square Edge	4.20
Work Surfaces, Hardwood, 1¼", Full-Radius Edge	4.21
Work Surfaces, Hardwood, 1¾", Square Edge	4.22
Work Surfaces, Stainless Steel	4.23
Surface B Support Brackets	4.24
Surface Cantilever Supports	4.25
Frame-Mount Surface Supports	4.26
Surface Reinforcement Bars	4.27
Surface Support Bar	4.28
Surface Accessory Brackets	4.29
Surface Back Stops	4.30
Phenolic Backsplashes	4.31
Surface Gap Fillers and Leveling Plates	4.32
Phenolic Gap Fillers	4.33
Corian Backsplashes	4.34
Epoxy Backsplashes	4.35
Auxiliary Surface	4.36

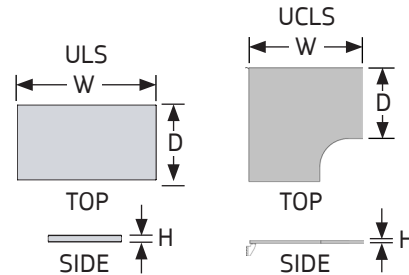

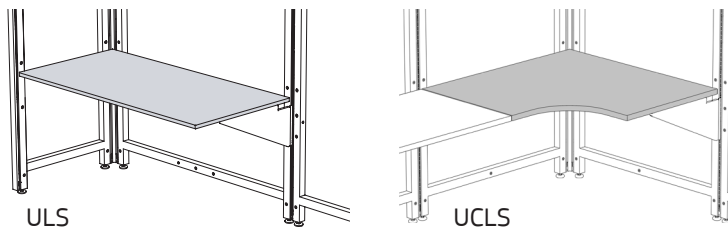

ULTRA SURFACES, STD. LAMINATE, SQUARE EDGE

- 1¼" tall, high pressure laminate surfaces mount to Panels, ErgoStats®, Table Bases and UltraFrames.
- Surfaces have square corners with matching square edge-band.
- Surfaces are predrilled for supports and most accessories.
- Corner surfaces include one corner bracket.
- Load capacity is 500 lb. capacity, evenly distributed.

NOTES

- » For corner surfaces order left- and right-side supports separately; see pages 4.24 - 4.26.
- » Surface supports sold separately; see pages 4.24 - 4.26.
- » 72" and 96" wide frame-mounted surfaces must be supported in the center by Surface Cantilever Supports. Specify one 18" cantilever per 24" and 30" deep surface and one 24" cantilever per 36" deep surface.

How to Specify

Step 1. Product Number

- ULS Rectangular Surface, Square Edge
- UCLS Corner Surface, Square Edge

Step 2. Depth

24 24" deep 30 30" deep 36 36" deep

Step 3. Width (Corner is 48" only)

24 24" wide 30 30" wide 36 36" wide
 48 48" wide 60 60" wide 72 72" wide
 96 96" wide

Step 4. Laminate Color Code

- AW Arctic White
- BK Black
- GF Grey Fleck
- GL Grey Light
- NW Neutral White
- SA Sand
- WF White Fleck

Product Number	Description	Height		Width		Depth		Weight	
		in.	[mm]	in.	[mm]	in.	[mm]	lb.	[kg]
ULS2424	Standard laminate, square edge	1 ¼	32	24	610	24	610	22	10.0
ULS2430	Standard laminate, square edge	1 ¼	32	30	762	24	610	24	10.9
ULS2436	Standard laminate, square edge	1 ¼	32	36	914	24	610	29	13.2
ULS2448	Standard laminate, square edge	1 ¼	32	48	1219	24	610	36	16.3
ULS2460	Standard laminate, square edge	1 ¼	32	60	1524	24	610	45	20.4
ULS2472	Standard laminate, square edge	1 ¼	32	72	1829	24	610	54	24.5
ULS2496	Standard laminate, square edge	1 ¼	32	96	2438	24	610	72	32.7
ULS3024	Standard laminate, square edge	1 ¼	32	24	610	30	762	24	10.9
ULS3030	Standard laminate, square edge	1 ¼	32	30	762	30	762	30	13.6
ULS3036	Standard laminate, square edge	1 ¼	32	36	914	30	762	36	16.3
ULS3048	Standard laminate, square edge	1 ¼	32	48	1219	30	762	45	20.4
ULS3060	Standard laminate, square edge	1 ¼	32	60	1524	30	762	56	25.4
ULS3072	Standard laminate, square edge	1 ¼	32	72	1829	30	762	67	30.4
ULS3096	Standard laminate, square edge	1 ¼	32	96	2438	30	762	90	40.8
ULS3624	Standard laminate, square edge	1 ¼	32	24	610	36	762	26	11.8
ULS3630	Standard laminate, square edge	1 ¼	32	30	762	36	914	36	16.3
ULS3636	Standard laminate, square edge	1 ¼	32	36	914	36	914	43	19.5
ULS3648	Standard laminate, square edge	1 ¼	32	48	1219	36	914	54	24.5
ULS3660	Standard laminate, square edge	1 ¼	32	60	1524	36	914	67	30.4
ULS3672	Standard laminate, square edge	1 ¼	32	72	1829	36	914	80	36.3
ULS3696	Standard laminate, square edge	1 ¼	32	96	2438	36	914	108	49.0
UCLS2448	Standard laminate, corner, square edge	1 ¼	32	48	1219	24	610	72	32.7
UCLS3048	Standard laminate, corner, square edge	1 ¼	32	48	1219	30	762	74	33.6
UCLS3648	Standard laminate, corner, square edge	1 ¼	32	48	1219	36	914	78	35.4

Rev 03/12/26

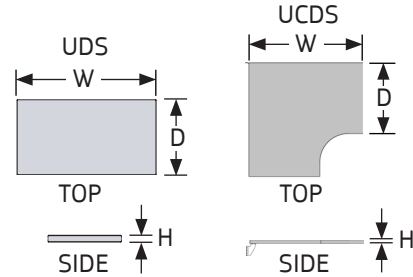
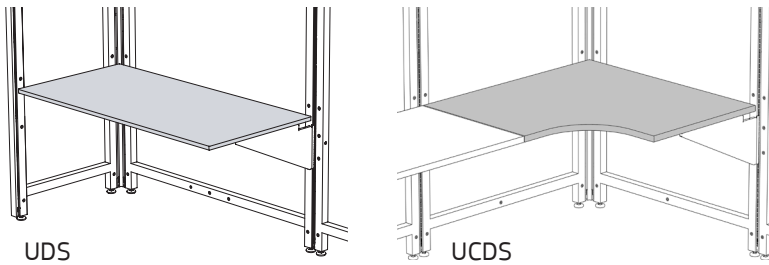

ULTRA SURFACES, ESD LAMINATE, SQUARE EDGE

- 1¼" tall high pressure laminate surfaces mount to ErgoStats®, Table Bases, UltraFrames and Panels.
- Symbiote dissipative surfaces are manufactured with Nevamar® Static Dissipative Laminates (SDL). Nevamar SDL is manufactured to have a point to point and point to ground resistance of 1 x 106 to 1 x 109 ohms @ 10-60% relative humidity. Nevamar SDL conforms to ESD Association Standard ESD-S4.1.
- Dissipative surfaces include a Laminate Grounding Terminal Kit.
- Surfaces have square corners with matching square edge-band.
- Corner surfaces include one corner bracket.
- Surfaces are predrilled for supports and most accessories.
- Load capacity is 500 lbs. evenly distributed.

NOTES

- » For corner surfaces order left- and right-side supports separately; see pages 4.24 - 4.26.
- » Surface supports sold separately; see pages 4.24 - 4.26.
- » 72" and 96" wide frame-mounted surfaces must be supported in the center by Surface Cantilever Supports. Specify one 18" cantilever per 24" and 30" deep surface and one 24" cantilever per 36" deep surface.
- » Customers are responsible for specifying ESD surface requirements; corporate ESD standards must be consulted prior to ordering.

How to Specify

Step 1. Product Number

- UDS Rectangular Surface, Square Edge
- UCDS Corner Surface, Square Edge

Step 2. Depth

- 24 24" deep 30 30" deep 36 36" deep

Step 3. Width (Corner is 48" only)

- 24 24" wide 30 30" wide 36 36" wide
- 48 48" wide 60 60" wide 72 72" wide
- 96 96" wide

Step 4. Laminate Color Code

- DBK Dissipative Black
- DG Dissipative Grey
- DNW Dissipative Neutral White
- DS Dissipative Sand
- DW Dissipative White

Product Number	Description	Height		Width		Depth		Weight	
		in.	[mm]	in.	[mm]	in.	[mm]	lb.	[kg]
UDS2424	ESD laminate, square edge	1 ¼	32	24	610	24	610	22	10.0
UDS2430	ESD laminate, square edge	1 ¼	32	30	762	24	610	24	10.9
UDS2436	ESD laminate, square edge	1 ¼	32	36	914	24	610	29	13.2
UDS2448	ESD laminate, square edge	1 ¼	32	48	1219	24	610	36	16.3
UDS2460	ESD laminate, square edge	1 ¼	32	60	1524	24	610	45	20.4
UDS2472	ESD laminate, square edge	1 ¼	32	72	1829	24	610	54	24.5
UDS2496	ESD laminate, square edge	1 ¼	32	96	2438	24	610	72	32.7
UDS3024	ESD laminate, square edge	1 ¼	32	24	610	30	762	24	10.9
UDS3030	ESD laminate, square edge	1 ¼	32	30	762	30	762	30	13.6
UDS3036	ESD laminate, square edge	1 ¼	32	36	914	30	762	36	16.3
UDS3048	ESD laminate, square edge	1 ¼	32	48	1219	30	762	45	20.4
UDS3060	ESD laminate, square edge	1 ¼	32	60	1524	30	762	56	25.4
UDS3072	ESD laminate, square edge	1 ¼	32	72	1829	30	762	67	30.4
UDS3096	ESD laminate, square edge	1 ¼	32	96	2438	30	762	90	40.8

Cont'd

ULTRA SURFACES, ESD LAMINATE, SQUARE EDGE (Cont'd)

Product Number	Description	Height		Width		Depth		Weight	
		in.	[mm]	in.	[mm]	in.	[mm]	lb.	[kg]
UDS3624	ESD laminate, square edge	1 ¼	32	24	610	36	762	26	11.8
UDS3630	ESD laminate, square edge	1 ¼	32	30	762	36	914	36	16.3
UDS3636	ESD laminate, square edge	1 ¼	32	36	914	36	914	43	19.5
UDS3648	ESD laminate, square edge	1 ¼	32	48	1219	36	914	54	24.5
UDS3660	ESD laminate, square edge	1 ¼	32	60	1524	36	914	67	30.4
UDS3672	ESD laminate, square edge	1 ¼	32	72	1829	36	914	80	36.3
UDS3696	ESD laminate, square edge	1 ¼	32	96	2438	36	914	108	49.0
UCDS2448	ESD laminate, corner, square edge	1 ¼	32	48	1219	24	610	72	32.7
UCDS3048	ESD laminate, corner, square edge	1 ¼	32	48	1219	30	762	74	33.6
UCDS3648	ESD laminate, corner, square edge	1 ¼	32	48	1219	36	914	78	35.4

Rev 03/12/26

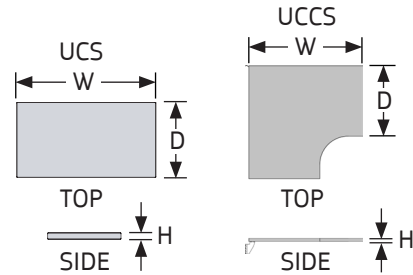
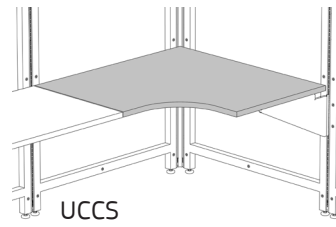
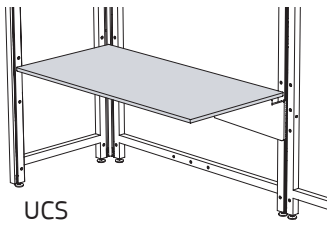

ULTRA SURFACES, CHEMSURF LAM., SQUARE EDGE

- 1¼" tall high pressure Chemsurf laminate surfaces are made for highly corrosive environments with exceptional chemical and wear resistance.
- Surfaces mount to ErgoStats®, Table Bases, UltraFrames and Panels.
- Surfaces have square corners with a matching square edge band.
- Surfaces are predrilled for supports and most accessories.
- Corner surfaces include one corner bracket.
- Load capacity 500 lbs. evenly distributed.

NOTES

- » For corner surfaces order left- and right-side supports separately; see pages 4.24 - 4.26.
- » Surface supports sold separately; see pages 4.24 - 4.26.
- » 72" and 96" wide frame-mounted surfaces must be supported in the center by Surface Cantilever Supports. Specify one 18" cantilever per 24" and 30" deep surface and one 24" cantilever per 36" deep surface.

How to Specify

Step 1. Product Number

- UCS Rectangular Surface, Square Edge
- UCCS Corner Surface, Square Edge

Step 2. Depth

- 24 24" deep 30 30" deep 36 36" deep

Step 3. Width (Corner is 48" only)

- 24 24" wide 30 30" wide 36 36" wide
- 48 48" wide 60 60" wide 72 72" wide
- 96 96" wide

Step 4. Laminate Color Code

- CBK Black
- CGL Grey Light
- CNW Neutral White

Product Number	Description	Height		Width		Depth		Weight	
		in.	[mm]	in.	[mm]	in.	[mm]	lb.	[kg]
UCS2424	Chemsurf laminate, square edge	1 ¼	32	24	610	24	610	22	10.0
UCS2430	Chemsurf laminate, square edge	1 ¼	32	30	762	24	610	24	10.9
UCS2436	Chemsurf laminate, square edge	1 ¼	32	36	914	24	610	29	13.2
UCS2448	Chemsurf laminate, square edge	1 ¼	32	48	1219	24	610	36	16.3
UCS2460	Chemsurf laminate, square edge	1 ¼	32	60	1524	24	610	45	20.4
UCS2472	Chemsurf laminate, square edge	1 ¼	32	72	1829	24	610	54	24.5
UCS2496	Chemsurf laminate, square edge	1 ¼	32	96	2438	24	610	72	32.7
UCS3024	Chemsurf laminate, square edge	1 ¼	32	24	610	30	762	24	10.9
UCS3030	Chemsurf laminate, square edge	1 ¼	32	30	762	30	762	30	13.6
UCS3036	Chemsurf laminate, square edge	1 ¼	32	36	914	30	762	36	16.3
UCS3048	Chemsurf laminate, square edge	1 ¼	32	48	1219	30	762	45	20.4
UCS3060	Chemsurf laminate, square edge	1 ¼	32	60	1524	30	762	56	25.4
UCS3072	Chemsurf laminate, square edge	1 ¼	32	72	1829	30	762	67	30.4
UCS3096	Chemsurf laminate, square edge	1 ¼	32	96	2438	30	762	90	40.8
UCS3624	Chemsurf laminate, square edge	1 ¼	32	24	610	36	762	26	11.8
UCS3630	Chemsurf laminate, square edge	1 ¼	32	30	762	36	914	36	16.3
UCS3636	Chemsurf laminate, square edge	1 ¼	32	36	914	36	914	43	19.5
UCS3648	Chemsurf laminate, square edge	1 ¼	32	48	1219	36	914	54	24.5
UCS3660	Chemsurf laminate, square edge	1 ¼	32	60	1524	36	914	67	30.4
UCS3672	Chemsurf laminate, square edge	1 ¼	32	72	1829	36	914	80	36.3
UCS3696	Chemsurf laminate, square edge	1 ¼	32	96	2438	36	914	108	49.0
UCCS2448	Chemsurf laminate, corner, square edge	1 ¼	32	48	1219	24	610	72	32.7
UCCS3048	Chemsurf laminate, corner, square edge	1 ¼	32	48	1219	30	762	74	33.6
UCCS3648	Chemsurf laminate, corner, square edge	1 ¼	32	48	1219	36	914	78	35.4

Rev 03/12/26

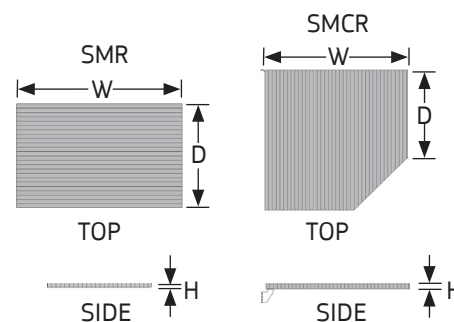
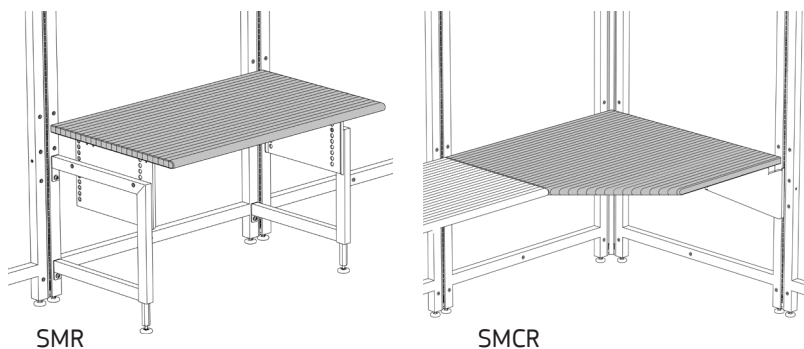

ULTRA SURFACES, HARDWOOD, 1¼" FULL RADIUS EDGE

- 1¼" tall Hardwood Surfaces mount to ErgoStats®, Table Bases, UltraFrames and Panels.
- Surfaces consist of kiln-dried hardwood strips that are face glued, sanded smooth and finished with a two coat catalyzed varnish.
- 1¼" tall Hardwood has a full radius front edge with square-edged backs and sides.
- Corner surfaces include one corner bracket.
- Surfaces are predrilled for supports and most accessories.
- Load capacity 500 lbs. evenly distributed.

NOTES

- » For corner surfaces order left- and right-side supports separately; see pages 4.24 - 4.26.
- » Surface supports sold separately; see pages 4.24 - 4.26.
- » 72" and 96" wide frame-mounted surfaces must be supported in the center by Surface Cantilever Supports. Specify one 18" cantilever per 30" deep surface and one 24" cantilever per 36" deep surface.

How to Specify

Step 1. Product Number

- SMR Rectangular Surface, Full Radius Edge
- SMCR Corner Surface, Full Radius Edge

Step 2. Depth

- 30 30" deep 36 36" deep

Step 3. Width (Corner is 48" only)

- 24 24" wide 30 30" wide 36 36" wide
- 48 48" wide 60 60" wide 72 72" wide
- 96 96" wide

Step 4. Color

- CC Hardwood

Product Number	Description	Height		Width		Depth		Weight	
		in.	[mm]	in.	[mm]	in.	[mm]	lb.	[kg]
SMR3024CC	Hardwood, 1¼", full-radius edge	1 ¼	32	24	610	30	610	25	11.3
SMR3030CC	Hardwood, 1¼", full-radius edge	1 ¼	32	30	762	30	610	31	14.1
SMR3036CC	Hardwood, 1¼", full-radius edge	1 ¼	32	36	914	30	610	38	17.2
SMR3048CC	Hardwood, 1¼", full-radius edge	1 ¼	32	48	1219	30	610	50	22.7
SMR3060CC	Hardwood, 1¼", full-radius edge	1 ¼	32	60	1524	30	610	63	28.6
SMR3072CC	Hardwood, 1¼", full-radius edge	1 ¼	32	72	1829	30	610	75	34.0
SMR3096CC	Hardwood, 1¼", full-radius edge	1 ¼	32	96	2438	30	610	100	45.4
SMR3636CC	Hardwood, 1¼", full-radius edge	1 ¼	32	36	914	36	914	45	20.4
SMR3648CC	Hardwood, 1¼", full-radius edge	1 ¼	32	48	1219	36	914	60	27.2
SMR3660CC	Hardwood, 1¼", full-radius edge	1 ¼	32	60	1524	36	914	75	34.0
SMR3672CC	Hardwood, 1¼", full-radius edge	1 ¼	32	72	1829	36	914	90	40.8
SMR3696CC	Hardwood, 1¼", full-radius edge	1 ¼	32	96	2438	36	914	120	54.4
SMCR3048CC	Hardwood, Corner, 1¼", full-radius edge	1 ¼	32	48	1219	30	762	74	33.6
SMCR3648CC	Hardwood, Corner, 1¼", full-radius edge	1 ¼	32	48	1219	36	914	78	35.4

Rev 03/12/26

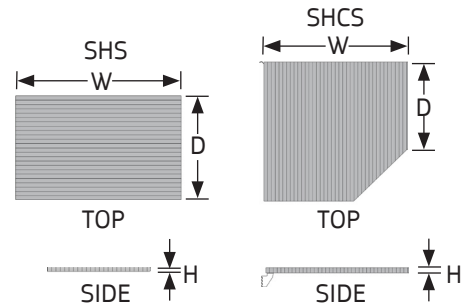
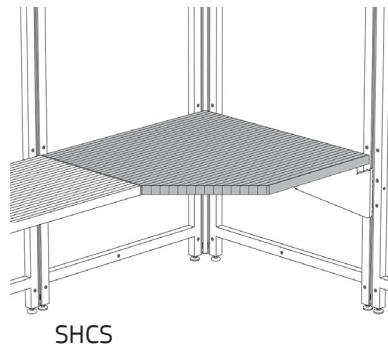
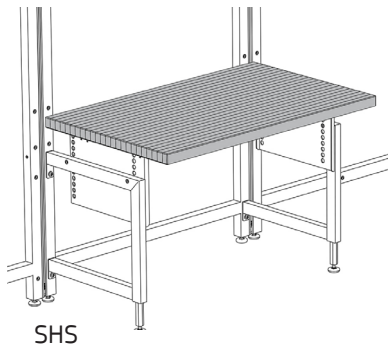

ULTRA SURFACES, HARDWOOD, 1 3/4" SQUARE EDGE

- 1 3/4" tall Hardwood Surfaces mount to ErgoStats®, Table Bases, UltraFrames and Panels.
- Surfaces consist of kiln-dried hardwood strips that are face glued, sanded smooth and finished with a two coat catalyzed varnish.
- 1 3/4" tall Hardwood has a square-edged front, back and sides.
- Corner surfaces include one corner bracket.
- Surfaces are predrilled for supports and most accessories.
- Load capacity 500 lbs. evenly distributed.

NOTES

- » For corner surfaces order left- and right-side supports separately; see pages 4.24 - 4.26.
- » Surface supports sold separately; see pages 4.24 - 4.26.
- » 72" and 96" wide frame-mounted surfaces must be supported in the center by Surface Cantilever Supports. Specify one 18" cantilever per 30" deep surface and one 24" cantilever per 36" deep surface.

How to Specify

Step 1. Product Number

- SHS Rectangular Surface, Square Edge
- SHCS Corner Surface, Square Edge

Step 2. Depth

- 30 30" deep 36 36" deep

Step 3. Width (Corner is 48" only)

- 24 24" wide 30 30" wide 36 36" wide
- 48 48" wide 60 60" wide 72 72" wide
- 96 96" wide

Step 4. Color

- CC Hardwood

Product Number	Description	Height		Width		Depth		Weight	
		in.	[mm]	in.	[mm]	in.	[mm]	lb.	[kg]
SHS3024CC	Hardwood, 1 3/4", square edge	1 3/4	44	24	610	30	610	35	15.9
SHS3030CC	Hardwood, 1 3/4", square edge	1 3/4	44	30	762	30	610	43	19.5
SHS3036CC	Hardwood, 1 3/4", square edge	1 3/4	44	36	914	30	610	53	24.0
SHS3048CC	Hardwood, 1 3/4", square edge	1 3/4	44	48	1219	30	610	70	31.8
SHS3060CC	Hardwood, 1 3/4", square edge	1 3/4	44	60	1524	30	610	88	39.9
SHS3072CC	Hardwood, 1 3/4", square edge	1 3/4	44	72	1829	30	610	105	47.6
SHS3096CC	Hardwood, 1 3/4", square edge	1 3/4	44	96	2438	30	610	140	63.5
SHS3636CC	Hardwood, 1 3/4", square edge	1 3/4	44	36	914	36	914	63	28.6
SHS3648CC	Hardwood, 1 3/4", square edge	1 3/4	44	48	1219	36	914	84	38.1
SHS3660CC	Hardwood, 1 3/4", square edge	1 3/4	44	60	1524	36	914	105	47.6
SHS3672CC	Hardwood, 1 3/4", square edge	1 3/4	44	72	1829	36	914	126	57.2
SHS3696CC	Hardwood, 1 3/4", square edge	1 3/4	44	96	2438	36	914	168	76.2
SHCS3048CC	Hardwood, Corner, 1 3/4", square edge	1 3/4	44	48	1219	30	762	104	47.2
SHCS3648CC	Hardwood, Corner, 1 3/4", square edge	1 3/4	44	48	1219	36	914	109	49.4

Rev 03/12/26

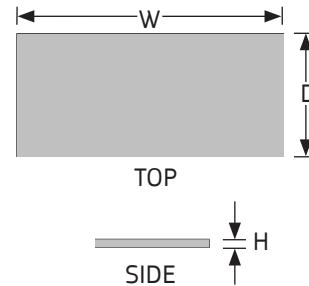
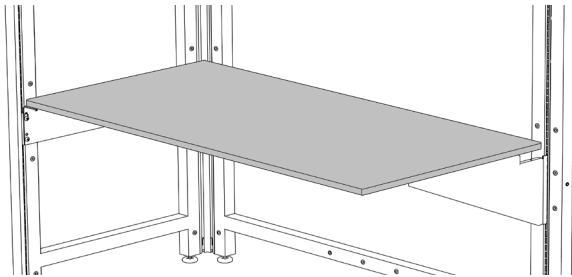

ULTRA SURFACES, STAINLESS STEEL

- Stainless Steel Surfaces are made for areas where high abrasion, chemical resistance and sterilization are required.
- Surfaces mount to ErgoStats®, Table Bases, WorkTables, UltraFrames and Panels.
- Manufactured using 16 gauge stainless steel with a #4 brush finish.
- Surface is constructed of a stainless steel "cap" (tops and sides are formed from one sheet of steel with welded corners) assembled to a core which is laminated with backer material. The joint between the cap and core is sealed around the full perimeter.
- Load capacity is 500 lbs. evenly distributed.

NOTES

- » Surface supports sold separately; see pages 4.24 - 4.26.
- » 72" and 96" wide frame-mounted surfaces must be supported in the center by Surface Cantilever Supports. Specify one 18" cantilever per 24" and 30" deep surface and one 24" cantilever per 36" deep surface.

How to Specify

Step 1. Product Number

USC Ultra Surface, Stainless Steel

Step 2. Depth

24 24" deep 30 30" deep 36 36" deep

Step 3. Width

36 36" wide 48 48" wide 60 60" wide
72 72" wide 96 96" wide

Product Number	Description	Height		Width		Depth		Weight	
		in.	[mm]	in.	[mm]	in.	[mm]	lb.	[kg]
USC2436	Stainless steel, square edge	1 1/8	28	36	914	24	610	44	20.0
USC2448	Stainless steel, square edge	1 1/8	29	48	1219	24	610	59	26.8
USC2460	Stainless steel, square edge	1 1/8	29	60	1524	24	610	73	33.1
USC2472	Stainless steel, square edge	1 1/8	29	72	1829	24	610	88	39.9
USC2496	Stainless steel, square edge	1 1/8	29	96	2438	24	610	117	53.1
USC3036	Stainless steel, square edge	1 1/8	29	36	914	30	762	55	24.9
USC3048	Stainless steel, square edge	1 1/8	29	48	1219	30	762	74	33.6
USC3060	Stainless steel, square edge	1 1/8	29	60	1524	30	762	92	41.7
USC3072	Stainless steel, square edge	1 1/8	29	72	1829	30	762	110	49.9
USC3096	Stainless steel, square edge	1 1/8	29	96	2438	30	762	147	66.7
USC3636	Stainless steel, square edge	1 1/8	29	36	914	36	914	66	29.9
USC3648	Stainless steel, square edge	1 1/8	29	48	1219	36	914	88	39.9
USC3660	Stainless steel, square edge	1 1/8	29	60	1524	36	914	110	49.9
USC3672	Stainless steel, square edge	1 1/8	29	72	1829	36	914	132	59.9
USC3696	Stainless steel, square edge	1 1/8	29	96	2438	36	914	176	79.8

Rev 03/12/26

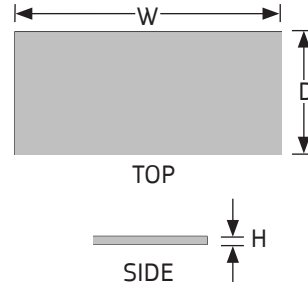
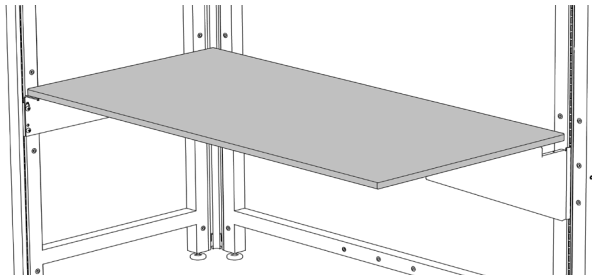

PHENOLIC SYSTEMS SURFACES

- 1" tall solid Phenolic Resin Surfaces are made for highly corrosive environments with exceptional chemical and wear resistance. Contact factory for detailed chemical resistance test data.
- Surfaces mount to ErgoStats®, Table Bases, WorkTables, UltraFrames and Panels.
- Surfaces have smooth 1/8" radius corners and are predrilled for end surface supports.
- Load capacity 300 lbs. evenly distributed.
- Finish is Black.

NOTES

- » Surface supports sold separately; see pages 4.24 - 4.26.
- » 72" and 96" wide frame-mounted surfaces must be supported in the center by Surface Cantilever Supports. Specify one 18" cantilever per 24" and 30" deep surface and one 24" cantilever per 36" deep surface.
- » Phenolic (undrilled) Lab Surfaces available; see Section 10.

How to Specify

Step 1. Product Number

TSP Phenolic Resin Surface

Step 2. Depth

24 24" deep 30 30" deep 36 36" deep

Step 3. Width

24 24" wide 30 30" wide 36 36" wide
 48 48" wide 60 60" wide 72 72" wide
 96 96" wide

Step 4. Color Code

BK Black

Product Number	Description	Height		Width		Depth		Weight	
		in.	[mm]	in.	[mm]	in.	[mm]	lb.	[kg]
TSP2424BK	Phenolic, 1/8" radius edge	1	25	24	610	24	610	29	13.2
TSP2430BK	Phenolic, 1/8" radius edge	1	25	30	762	24	610	36	16.3
TSP2436BK	Phenolic, 1/8" radius edge	1	25	36	914	24	610	43	19.5
TSP2448BK	Phenolic, 1/8" radius edge	1	25	48	1219	24	610	58	26.3
TSP2460BK	Phenolic, 1/8" radius edge	1	25	60	1524	24	610	72	32.7
TSP2472BK	Phenolic, 1/8" radius edge	1	25	72	1829	24	610	86	39.0
TSP2496BK	Phenolic, 1/8" radius edge	1	25	96	2438	24	610	115	52.2
TSP3024BK	Phenolic, 1/8" radius edge	1	25	24	610	30	762	36	16.3
TSP3030BK	Phenolic, 1/8" radius edge	1	25	30	762	30	762	45	20.4
TSP3036BK	Phenolic, 1/8" radius edge	1	25	36	914	30	762	54	24.5
TSP3048BK	Phenolic, 1/8" radius edge	1	25	48	1219	30	762	72	32.7
TSP3060BK	Phenolic, 1/8" radius edge	1	25	60	1524	30	762	90	40.8
TSP3072BK	Phenolic, 1/8" radius edge	1	25	72	1829	30	762	108	49.0
TSP3096BK	Phenolic, 1/8" radius edge	1	25	96	2438	30	762	144	65.3
TSP3624BK	Phenolic, 1/8" radius edge	1	25	24	610	30	762	43	19.5
TSP3630BK	Phenolic, 1/8" radius edge	1	25	30	762	36	914	54	24.5
TSP3636BK	Phenolic, 1/8" radius edge	1	25	36	914	36	914	65	29.5
TSP3648BK	Phenolic, 1/8" radius edge	1	25	48	1219	36	914	86	39.0
TSP3660BK	Phenolic, 1/8" radius edge	1	25	60	1524	36	914	108	49.0
TSP3672BK	Phenolic, 1/8" radius edge	1	25	72	1829	36	914	130	59.0
TSP3696BK	Phenolic, 1/8" radius edge	1	25	96	2438	36	914	173	78.5

Rev 03/12/26

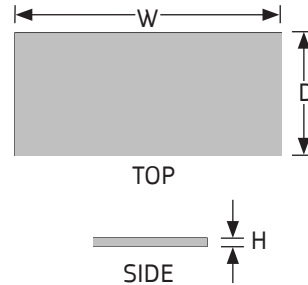
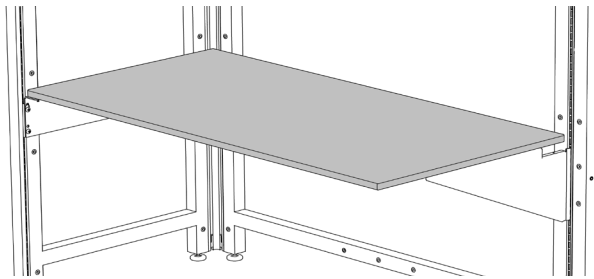

CORIAN SYSTEMS SURFACES

- 1.25" high Corian work surfaces have a .75" thick particle board core with a white malamine backer and .50" thick Corian.
- Corian work surfaces are used in areas where high chemical resistance and wear resistance are required.
- Surfaces mount to ErgoStats®, Table Bases, WorkTables, Tetrad Tables and UltraFrames.
- Surfaces have a square edge and are pre-drilled for end surface supports.
- Load capacity 300 lbs. evenly distributed.

NOTES

- » For corner surfaces order left- and right-side supports separately; see pages 4.24 - 4.26.
- » Surface supports sold separately; see pages 4.24 - 4.26.
- » 72" and 96" wide frame-mounted surfaces must be supported in the center by Surface Cantilever Supports. Specify one 18" cantilever per 24" and 30" deep surface and one 24" cantilever per 36" deep surface.

How to Specify

Step 1. Product Number

TSKR Rectangular

Step 2. Depth

24 24" deep 30 30" deep 36 36" deep

Step 3. Width

24 24" wide 30 30" wide 36 36" wide
 48 48" wide 60 60" wide 72 72" wide
 96 96" wide

Step 4. Corian Color Code

SAE Artista Beige GRD 2 SDN Deep Nocturne GRD 3
 SAG Artista Gray GRD 2 SGX Gray Onyx GRD 4
 SBQ Bisque GRD 1 SMW Modern White GRD 2

Product Number	Description	Height		Width		Depth		Weight	
		in.	[mm]	in.	[mm]	in.	[mm]	lb.	[kg]
TSKR2424	Corian, square edge	1 ¼	32	24	610	24	610	27	12.4
TSKR2430	Corian, square edge	1 ¼	32	30	762	24	610	34	15.5
TSKR2436	Corian, square edge	1 ¼	32	36	914	24	610	41	18.6
TSKR2448	Corian, square edge	1 ¼	32	48	1219	24	610	55	24.8
TSKR2460	Corian, square edge	1 ¼	32	60	1524	24	610	68	31.0
TSKR2472	Corian, square edge	1 ¼	32	72	1829	24	610	82	37.2
TSKR2496	Corian, square edge	1 ¼	32	96	2438	24	610	109	49.6
TSKR3024	Corian, square edge	1 ¼	32	24	610	30	762	34	15.5
TSKR3030	Corian, square edge	1 ¼	32	30	762	30	762	43	19.4
TSKR3036	Corian, square edge	1 ¼	32	36	914	30	762	51	23.2
TSKR3048	Corian, square edge	1 ¼	32	48	1219	30	762	68	31.0
TSKR3060	Corian, square edge	1 ¼	32	60	1524	30	762	86	38.7
TSKR3072	Corian, square edge	1 ¼	32	72	1829	30	762	103	46.5
TSKR3096	Corian, square edge	1 ¼	32	96	2438	30	762	137	61.9
TSKR3624	Corian, square edge	1 ¼	32	24	610	36	914	41	18.6
TSKR3630	Corian, square edge	1 ¼	32	30	762	36	914	51	23.2
TSKR3636	Corian, square edge	1 ¼	32	36	914	36	914	62	27.9
TSKR3648	Corian, square edge	1 ¼	32	48	1219	36	914	82	37.2
TSKR3660	Corian, square edge	1 ¼	32	60	1524	36	914	103	46.5
TSKR3672	Corian, square edge	1 ¼	32	72	1829	36	914	123	55.8
TSKR3696	Corian, square edge	1 ¼	32	96	2438	36	914	164	74.3

Rev 03/12/26

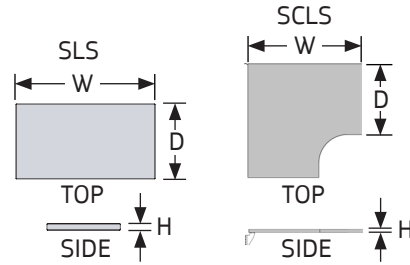
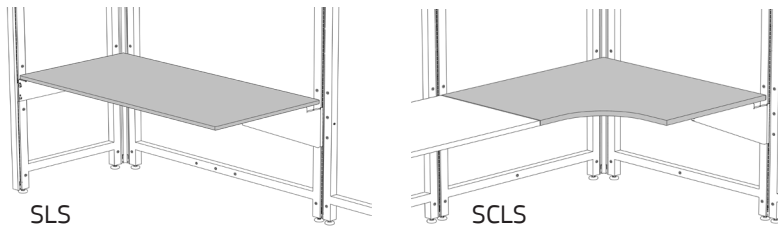

STD. SURFACES, STD. LAMINATE, SQUARE EDGE

- 1¼" tall high pressure laminate rectangular and corner surfaces mount to ErgoStats®, Table Bases, UltraFrames and Panels.
- Surfaces have square corners with matching square edge band.
- Surfaces are predrilled for supports and most accessories.
- Corner surfaces include one corner bracket.
- Load capacity 300 lbs. evenly distributed.

NOTES

- » For corner surfaces order left- and right-side supports separately; see pages 4.24 - 4.26.
- » Surface supports sold separately; see pages 4.24 - 4.26.
- » 72" and 96" wide frame-mounted surfaces must be supported in the center by Surface Cantilever Supports. Specify one 18" cantilever per 24" and 30" deep surface and one 24" cantilever per 36" deep surface.

How to Specify

Step 1. Product Number

- SLS Rectangular Surface, Square Edge
- SCLS Corner Surface, Square Edge

Step 2. Depth

- 24 24" deep 30 30" deep 36 36" deep

Step 3. Width (Corner is 48" only)

- 24 24" wide 30 30" wide 36 36" wide
- 48 48" wide 60 60" wide 72 72" wide
- 96 96" wide

Step 4. Laminate Color Code

- AW Arctic White
- BK Black
- GF Grey Fleck
- GL Grey Light
- NW Neutral White
- SA Sand
- WF White Fleck

Product Number	Description	Height		Width		Depth		Weight	
		in.	[mm]	in.	[mm]	in.	[mm]	lb.	[kg]
SLS2424	Standard laminate, square edge	1 ¼	32	24	610	24	610	22	10.0
SLS2430	Standard laminate, square edge	1 ¼	32	30	762	24	610	24	10.9
SLS2436	Standard laminate, square edge	1 ¼	32	36	914	24	610	29	13.2
SLS2448	Standard laminate, square edge	1 ¼	32	48	1219	24	610	36	16.3
SLS2460	Standard laminate, square edge	1 ¼	32	60	1524	24	610	45	20.4
SLS2472	Standard laminate, square edge	1 ¼	32	72	1829	24	610	54	24.5
SLS2496	Standard laminate, square edge	1 ¼	32	96	2438	24	610	72	32.7
SLS3024	Standard laminate, square edge	1 ¼	32	24	610	30	762	24	10.9
SLS3030	Standard laminate, square edge	1 ¼	32	30	762	30	762	30	13.6
SLS3036	Standard laminate, square edge	1 ¼	32	36	914	30	762	36	16.3
SLS3048	Standard laminate, square edge	1 ¼	32	48	1219	30	762	45	20.4
SLS3060	Standard laminate, square edge	1 ¼	32	60	1524	30	762	56	25.4
SLS3072	Standard laminate, square edge	1 ¼	32	72	1829	30	762	67	30.4
SLS3096	Standard laminate, square edge	1 ¼	32	96	2438	30	762	90	40.8
SLS3624	Standard laminate, square edge	1 ¼	32	24	610	36	914	26	11.8
SLS3630	Standard laminate, square edge	1 ¼	32	30	762	36	914	36	16.3
SLS3636	Standard laminate, square edge	1 ¼	32	36	914	36	914	43	19.5
SLS3648	Standard laminate, square edge	1 ¼	32	48	1219	36	914	54	24.5
SLS3660	Standard laminate, square edge	1 ¼	32	60	1524	36	914	67	30.4
SLS3672	Standard laminate, square edge	1 ¼	32	72	1829	36	914	80	36.3
SLS3696	Standard laminate, square edge	1 ¼	32	96	2438	36	914	108	49.0
SCLS2448	Standard laminate, corner, square edge	1 ¼	32	48	1219	24	610	72	32.7
SCLS3048	Standard laminate, corner, square edge	1 ¼	32	48	1219	30	762	74	33.6
SCLS3648	Standard laminate, corner, square edge	1 ¼	32	48	1219	36	914	78	35.4

Rev 03/12/26

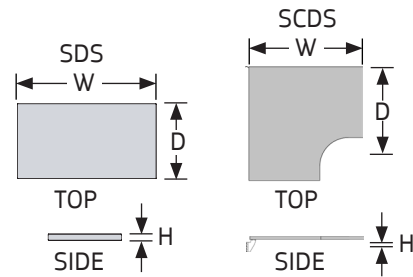
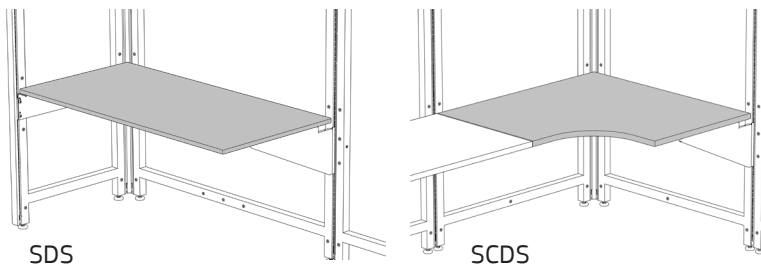

STD. SURFACES, ESD LAMINATE, SQUARE EDGE

- 1¼" tall high pressure ESD laminate surfaces mount to ErgoStats®, Table Bases, UltraFrames and Panels.
- Symbiote dissipative surfaces are manufactured with Nevamar® Static Dissipative Laminates (SDL). Nevamar SDL is manufactured to have a point to point and point to ground resistance of 1 x 10⁶ to 1 x 10⁹ ohms @ 10-60% relative humidity. Nevamar SDL conforms to ESD Association Standard ESD-S4.1.
- Dissipative Surfaces include a Laminate Grounding Terminal Kit.
- Surfaces have square corners with matching square edge-band.
- Corner surfaces include one corner bracket.
- Surfaces are predrilled for supports and most accessories.
- Load capacity 300 lbs. evenly distributed.

NOTES

- » Corner surfaces ship with one corner bracket. Order left- and right-side supports separately; see pages 4.24 - 4.26.
- » Surface supports sold separately; see pages 4.24 - 4.26.
- » 72" and 96" wide frame-mounted surfaces must be supported in the center by Surface Cantilever Supports. Specify one 18" cantilever per 24" and 30" deep surface and one 24" cantilever per 36" deep surface.
- » Customers are responsible for specifying ESD surface requirements; corporate ESD standards must be consulted prior to ordering.

How to Specify

Step 1. Product Number

- SDS Rectangular Surface, Square Edge
- SCDS Corner Surface, Square Edge

Step 2. Depth

- 24 24" deep 30 30" deep 36 36" deep

Step 3. Width (Corner is 48" only)

- 24 24" wide 30 30" wide 36 36" wide
- 48 48" wide 60 60" wide 72 72" wide
- 96 96" wide

Step 4. Laminate Color Code

- DBK Dissipative Black
- DG Dissipative Grey
- DNW Dissipative Neutral White
- DS Dissipative Sand
- DW Dissipative White

Product Number	Description	Height		Width		Depth		Weight	
		in.	[mm]	in.	[mm]	in.	[mm]	lb.	[kg]
SDS2424	ESD laminate, square edge	1 ¼	32	24	610	24	610	22	10.0
SDS2430	ESD laminate, square edge	1 ¼	32	30	762	24	610	24	10.9
SDS2436	ESD laminate, square edge	1 ¼	32	36	914	24	610	29	13.2
SDS2448	ESD laminate, square edge	1 ¼	32	48	1219	24	610	36	16.3
SDS2460	ESD laminate, square edge	1 ¼	32	60	1524	24	610	45	20.4
SDS2472	ESD laminate, square edge	1 ¼	32	72	1829	24	610	54	24.5
SDS2496	ESD laminate, square edge	1 ¼	32	96	2438	24	610	72	32.7
SDS3024	ESD laminate, square edge	1 ¼	32	24	610	30	762	24	10.9
SDS3030	ESD laminate, square edge	1 ¼	32	30	762	30	762	30	13.6
SDS3036	ESD laminate, square edge	1 ¼	32	36	914	30	762	36	16.3

Cont'd

STD. SURFACES, ESD LAMINATE, SQUARE EDGE (Cont'd)

Product Number	Description	Height		Width		Depth		Weight	
		in.	[mm]	in.	[mm]	in.	[mm]	lb.	[kg]
SDS3048	ESD laminate, square edge	1 ¼	32	48	1219	30	762	45	20.4
SDS3060	ESD laminate, square edge	1 ¼	32	60	1524	30	762	56	25.4
SDS3072	ESD laminate, square edge	1 ¼	32	72	1829	30	762	67	30.4
SDS3096	ESD laminate, square edge	1 ¼	32	96	2438	30	762	90	40.8
SDS3624	ESD laminate, square edge	1 ¼	32	24	610	36	762	26	11.8
SDS3630	ESD laminate, square edge	1 ¼	32	30	762	36	914	36	16.3
SDS3636	ESD laminate, square edge	1 ¼	32	36	914	36	914	43	19.5
SDS3648	ESD laminate, square edge	1 ¼	32	48	1219	36	914	54	24.5
SDS3660	ESD laminate, square edge	1 ¼	32	60	1524	36	914	67	30.4
SDS3672	ESD laminate, square edge	1 ¼	32	72	1829	36	914	80	36.3
SDS3696	ESD laminate, square edge	1 ¼	32	96	2438	36	914	108	49.0
SCDS2448	ESD laminate, corner, square edge	1 ¼	32	48	1219	24	610	72	32.7
SCDS3048	ESD laminate, corner, square edge	1 ¼	32	48	1219	30	762	74	33.6
SCDS3648	ESD laminate, corner, square edge	1 ¼	32	48	1219	36	914	78	35.4

Rev 03/12/26

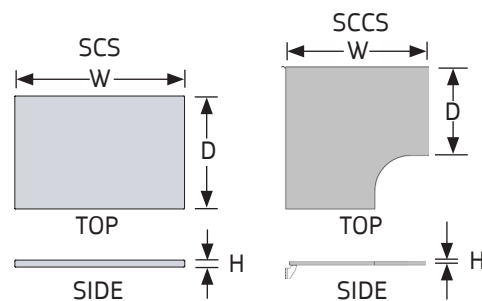
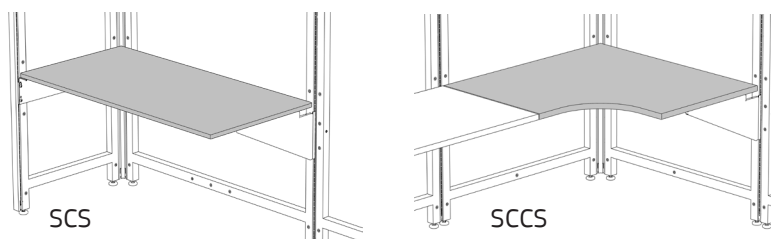

STD. SURFACES, CHEMSURF LAM., SQUARE EDGE

- 1¼" tall high pressure Chemsurf laminate surfaces are made for highly corrosive environments with exceptional chemical and wear resistance.
- Surfaces mount to ErgoStats®, Table Bases, UltraFrames and Panels.
- Surfaces have square corners with a matching square edge-band.
- Surfaces are predrilled for supports and most accessories.
- Corner surfaces include one corner bracket.
- Load capacity 300 lbs. evenly distributed.

NOTES

- » Corner surfaces ship with one corner bracket. Order left- and right-side supports separately; see pages 4.24 - 4.26.
- » Surface supports sold separately; see pages 4.24 - 4.26.
- » 72" and 96" wide frame-mounted surfaces must be supported in the center by Surface Cantilever Supports. Specify one 18" cantilever per 24" and 30" deep surface and one 24" cantilever per 36" deep surface.

How to Specify

Step 1. Product Number

- SCS Rectangular Surface, Square Edge
- SCCS Corner Surface, Square Edge

Step 2. Depth

- 24 24" deep 30 30" deep 36 36" deep

Step 3. Width (Corner is 48" only)

- 24 24" wide 30 30" wide 36 36" wide
- 48 48" wide 60 60" wide 72 72" wide
- 96 96" wide

Step 4. Chemsurf Laminate Color Code

- CBK Black
- CGL Grey Light
- CNW Neutral White

Product Number	Description	Height		Width		Depth		Weight	
		in.	[mm]	in.	[mm]	in.	[mm]	lb.	[kg]
SCS2424	Chemsurf laminate, square edge	1 ¼	32	24	610	24	610	22	10.0
SCS2430	Chemsurf laminate, square edge	1 ¼	32	30	762	24	610	24	10.9
SCS2436	Chemsurf laminate, square edge	1 ¼	32	36	914	24	610	29	13.2
SCS2448	Chemsurf laminate, square edge	1 ¼	32	48	1219	24	610	36	16.3
SCS2460	Chemsurf laminate, square edge	1 ¼	32	60	1524	24	610	45	20.4
SCS2472	Chemsurf laminate, square edge	1 ¼	32	72	1829	24	610	54	24.5
SCS2496	Chemsurf laminate, square edge	1 ¼	32	96	2438	24	610	72	32.7
SCS3024	Chemsurf laminate, square edge	1 ¼	32	24	610	30	762	24	10.9
SCS3030	Chemsurf laminate, square edge	1 ¼	32	30	762	30	762	30	13.6
SCS3036	Chemsurf laminate, square edge	1 ¼	32	36	914	30	762	36	16.3
SCS3048	Chemsurf laminate, square edge	1 ¼	32	48	1219	30	762	45	20.4
SCS3060	Chemsurf laminate, square edge	1 ¼	32	60	1524	30	762	56	25.4
SCS3072	Chemsurf laminate, square edge	1 ¼	32	72	1829	30	762	67	30.4
SCS3096	Chemsurf laminate, square edge	1 ¼	32	96	2438	30	762	90	40.8
SCS3624	Chemsurf laminate, square edge	1 ¼	32	24	610	36	762	26	11.8
SCS3630	Chemsurf laminate, square edge	1 ¼	32	30	762	36	914	36	16.3
SCS3636	Chemsurf laminate, square edge	1 ¼	32	36	914	36	914	43	19.5
SCS3648	Chemsurf laminate, square edge	1 ¼	32	48	1219	36	914	54	24.5
SCS3660	Chemsurf laminate, square edge	1 ¼	32	60	1524	36	914	67	30.4
SCS3672	Chemsurf laminate, square edge	1 ¼	32	72	1829	36	914	80	36.3
SCS3696	Chemsurf laminate, square edge	1 ¼	32	96	2438	36	914	108	49.0
SCCS2448	Chemsurf laminate, corner, square edge	1 ¼	32	48	1219	24	610	72	32.7
SCCS3048	Chemsurf laminate, corner, square edge	1 ¼	32	48	1219	30	762	74	33.6
SCCS3648	Chemsurf laminate, corner, square edge	1 ¼	32	48	1219	36	914	78	35.4

Rev 03/12/26

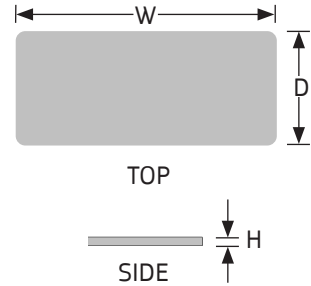
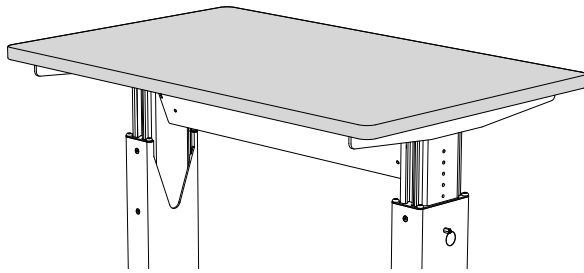

WORK SURFACES, STANDARD LAMINATE, T-EDGE

- 1¼" tall high pressure laminate surfaces mount to WorkTable Bases or 4-Legged Tables to construct a height adjustable table.
- Surfaces have matching vinyl T-edge around the full perimeter (with 1" radius corners).
- 30" deep Work Surfaces do not accept surface mounted accessories deeper than 12".
- 36" deep Work Surfaces do not accept surface mounted accessories deeper than 15".
- 42" deep Work Surfaces do not accept surface mounted accessories deeper than 18".
- 48" deep Work Surfaces do not accept surface mounted accessories deeper than 21".
- Load capacity 500 lbs. evenly distributed.

How to Specify

Step 1. Product Number

WLT Work Surface, Std. Laminate, T-Edge

Step 2. Depth

30 30" deep 36 36" deep 42 42" deep
48 48" deep

Step 3. Width

48 48" wide 60 60" wide 72 72" wide
96 96" wide

Step 4. Laminate Color Code

AW Arctic White	NW Neutral White
BK Black	SA Sand
GF Grey Fleck	WF White Fleck
GL Grey Light	

Product Number	Description	Height		Width		Depth		Weight	
		in.	[mm]	in.	[mm]	in.	[mm]	lb.	[kg]
WLT3048	Standard laminate, t-edge	1 ¼	32	48	1219	30	762	45	20.4
WLT3060	Standard laminate, t-edge	1 ¼	32	60	1524	30	762	56	25.4
WLT3072	Standard laminate, t-edge	1 ¼	32	72	1829	30	762	67	30.4
WLT3096	Standard laminate, t-edge	1 ¼	32	96	2438	30	762	90	40.8
WLT3648	Standard laminate, t-edge	1 ¼	32	48	1219	36	914	54	24.5
WLT3660	Standard laminate, t-edge	1 ¼	32	60	1524	36	914	67	30.4
WLT3672	Standard laminate, t-edge	1 ¼	32	72	1829	36	914	80	36.3
WLT3696	Standard laminate, t-edge	1 ¼	32	96	2438	36	914	108	49.0
WLT4248	Standard laminate, t-edge	1 ¼	32	48	1219	42	1067	63	28.6
WLT4260	Standard laminate, t-edge	1 ¼	32	60	1524	42	1067	78	35.4
WLT4272	Standard laminate, t-edge	1 ¼	32	72	1829	42	1067	93	42.2
WLT4296	Standard laminate, t-edge	1 ¼	32	96	2438	42	1067	126	57.2
WLT4848	Standard laminate, t-edge	1 ¼	32	48	1219	48	1219	72	32.7
WLT4860	Standard laminate, t-edge	1 ¼	32	60	1524	48	1219	89	40.4
WLT4872	Standard laminate, t-edge	1 ¼	32	72	1829	48	1219	107	48.5
WLT4896	Standard laminate, t-edge	1 ¼	32	96	2438	48	1219	144	65.3

Rev 06/20/24

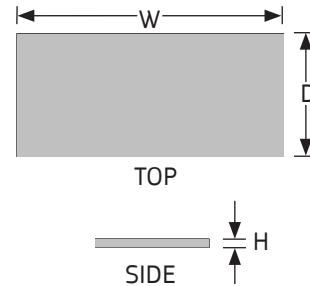
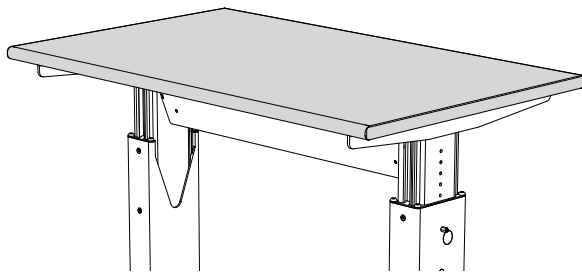

WORK SURFACES, STD. LAMINATE, SQUARE EDGE

- 1¼" tall high pressure laminate surfaces mount to WorkTable Bases or 4-Legged Tables to construct a height adjustable table.
- Matching vinyl square edge-banding.
- 30" deep Work Surfaces do not accept surface mounted accessories deeper than 12".
- 36" deep Work Surfaces do not accept surface mounted accessories deeper than 15".
- 42" deep Work Surfaces do not accept surface mounted accessories deeper than 18".
- 48" deep Work Surfaces do not accept surface mounted accessories deeper than 21".
- Load capacity 500 lbs. evenly distributed.

How to Specify

Step 1. Product Number

WLS Work Surface, Std. Laminate, SQ Edge

Step 2. Depth

30 30" deep 36 36" deep 42 42" deep
48 48" deep

Step 3. Width

48 48" wide 60 60" wide 72 72" wide
96 96" wide

Step 4. Laminate Color Code

AW Arctic White	NW Neutral White
BK Black	SA Sand
GF Grey Fleck	WF White Fleck
GL Grey Light	

Product Number	Description	Height		Width		Depth		Weight	
		in.	[mm]	in.	[mm]	in.	[mm]	lb.	[kg]
WLS3048	Standard laminate, square edge	1 ¼	32	48	1219	30	762	45	20.4
WLS3060	Standard laminate, square edge	1 ¼	32	60	1524	30	762	56	25.4
WLS3072	Standard laminate, square edge	1 ¼	32	72	1829	30	762	67	30.4
WLS3096	Standard laminate, square edge	1 ¼	32	96	2438	30	762	90	40.8
WLS3648	Standard laminate, square edge	1 ¼	32	48	1219	36	914	54	24.5
WLS3660	Standard laminate, square edge	1 ¼	32	60	1524	36	914	67	30.4
WLS3672	Standard laminate, square edge	1 ¼	32	72	1829	36	914	80	36.3
WLS3696	Standard laminate, square edge	1 ¼	32	96	2438	36	914	108	49.0
WLS4248	Standard laminate, square edge	1 ¼	32	48	1219	42	1067	63	28.6
WLS4260	Standard laminate, square edge	1 ¼	32	60	1524	42	1067	78	35.4
WLS4272	Standard laminate, square edge	1 ¼	32	72	1829	42	1067	93	42.2
WLS4296	Standard laminate, square edge	1 ¼	32	96	2438	42	1067	126	57.2
WLS4848	Standard laminate, square edge	1 ¼	32	48	1219	48	1219	72	32.7
WLS4860	Standard laminate, square edge	1 ¼	32	60	1524	48	1219	89	40.4
WLS4872	Standard laminate, square edge	1 ¼	32	72	1829	48	1219	107	48.5
WLS4896	Standard laminate, square edge	1 ¼	32	96	2438	48	1219	144	65.3

Rev 10/20/25

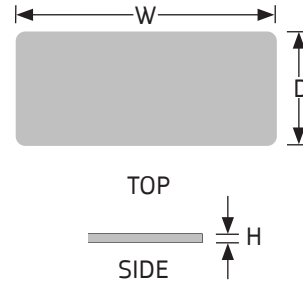
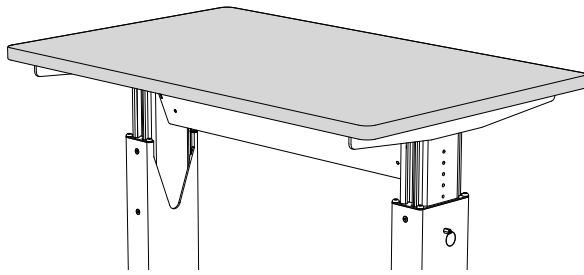

WORK SURFACES, ESD LAMINATE, T-EDGE

- 1¼" tall high pressure laminate surfaces mount to WorkTable Bases or 4-Legged Tables to construct a height adjustable table.
- Each surface includes a Laminate Grounding Terminal Kit (72" and 96" surfaces have two).
- Nevamar® Static Dissipative Laminates (SDL) conform to ESD Association Standard ESD-S4. SDL has a point to point and point to ground resistance of 1x106 to 1x109 ohms @10-60% relative humidity.
- Surfaces have a matching vinyl T-edge around the full perimeter (with 1" radius corners).
- 30" deep Work Surfaces do not accept surface mounted accessories deeper than 12".
- 36" deep Work Surfaces do not accept surface mounted accessories deeper than 15".
- 42" deep Work Surfaces do not accept surface mounted accessories deeper than 18".
- 48" deep Work Surfaces do not accept surface mounted accessories deeper than 21".
- Load capacity 500 lbs. evenly distributed.

NOTES

» Customers are responsible for specifying ESD surface requirements; corporate ESD standards must be consulted prior to ordering.

How to Specify

Step 1. Product Number

WDT ESD Laminate, T-Edge

Step 2. Depth

30 30" deep 36 36" deep 42 42" deep
48 48" deep

Step 3. Width

48 48" wide 60 60" wide 72 72" wide
96 96" wide

Step 4. Laminate Color Code

- DBK Dissipative Black
- DG Dissipative Grey
- DNW Dissipative Neutral White
- DS Dissipative Sand
- DW Dissipative White

Product Number	Description	Height		Width		Depth		Weight	
		in.	[mm]	in.	[mm]	in.	[mm]	lb.	[kg]
WDT3048	ESD laminate, t-edge	1 ¼	32	48	1219	30	762	45	20.4
WDT3060	ESD laminate, t-edge	1 ¼	32	60	1524	30	762	56	25.4
WDT3072	ESD laminate, t-edge	1 ¼	32	72	1829	30	762	67	30.4
WDT3096	ESD laminate, t-edge	1 ¼	32	96	2438	30	762	90	40.8
WDT3648	ESD laminate, t-edge	1 ¼	32	48	1219	36	914	54	24.5
WDT3660	ESD laminate, t-edge	1 ¼	32	60	1524	36	914	67	30.4
WDT3672	ESD laminate, t-edge	1 ¼	32	72	1829	36	914	80	36.3
WDT3696	ESD laminate, t-edge	1 ¼	32	96	2438	36	914	108	49.0
WDT4248	ESD laminate, t-edge	1 ¼	32	48	1219	42	1067	63	28.6
WDT4260	ESD laminate, t-edge	1 ¼	32	60	1524	42	1067	78	35.4
WDT4272	ESD laminate, t-edge	1 ¼	32	72	1829	42	1067	93	42.2
WDT4296	ESD laminate, t-edge	1 ¼	32	96	2438	42	1067	126	57.2
WDT4848	ESD laminate, t-edge	1 ¼	32	48	1219	48	1219	72	32.7
WDT4860	ESD laminate, t-edge	1 ¼	32	60	1524	48	1219	89	40.4
WDT4872	ESD laminate, t-edge	1 ¼	32	72	1829	48	1219	107	48.5
WDT4896	ESD laminate, t-edge	1 ¼	32	96	2438	48	1219	144	65.3

Rev 09/24/20

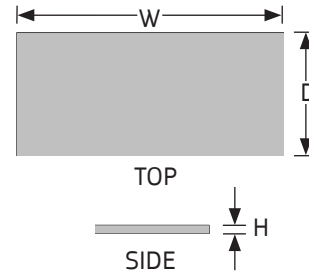
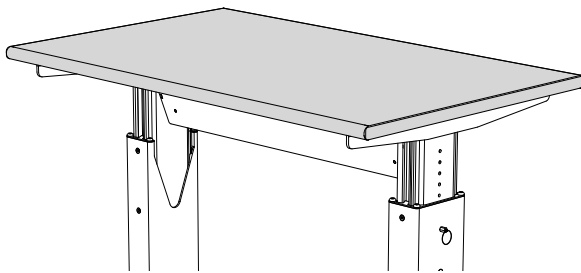

WORK SURFACES, ESD LAMINATE, SQUARE EDGE

- 1¼" tall high pressure laminate surfaces mount to WorkTable Bases or 4-Legged Tables to construct a height adjustable table.
- Each surface includes a Laminate Grounding Terminal Kit (72" and 96" surfaces have two).
- Nevamar® Static Dissipative Laminates (SDL) conform to ESD Association Standard ESD-S4. SDL has a point to point and point to ground resistance of 1x106 to 1x109 ohms @10-60% relative humidity.
- Surfaces have a matching vinyl square edge-banding.
- 30" deep Work Surfaces do not accept surface mounted accessories deeper than 12".
- 36" deep Work Surfaces do not accept surface mounted accessories deeper than 15".
- 42" deep Work Surfaces do not accept surface mounted accessories deeper than 18".
- 48" deep Work Surfaces do not accept surface mounted accessories deeper than 21".
- Load capacity 500 lbs. evenly distributed.

NOTES

- » Customers are responsible for specifying ESD surface requirements; corporate ESD standards must be consulted prior to ordering.

How to Specify

Step 1. Product Number

WDS ESD Laminate, Square Edge

Step 2. Depth

30 30" deep 36 36" deep 42 42" deep
48 48" deep

Step 3. Width

48 48" wide 60 60" wide 72 72" wide
96 96" wide

Step 4. Laminate Color Code

DBK Dissipative Black
DG Dissipative Grey
DNW Dissipative Neutral White
DS Dissipative Sand
DW Dissipative White

Product Number	Description	Height		Width		Depth		Weight	
		in.	[mm]	in.	[mm]	in.	[mm]	lb.	[kg]
WDS3048	ESD laminate, square edge	1 ¼	32	48	1219	30	762	45	20.4
WDS3060	ESD laminate, square edge	1 ¼	32	60	1524	30	762	56	25.4
WDS3072	ESD laminate, square edge	1 ¼	32	72	1829	30	762	67	30.4
WDS3096	ESD laminate, square edge	1 ¼	32	96	2438	30	762	90	40.8
WDS3648	ESD laminate, square edge	1 ¼	32	48	1219	36	914	54	24.5
WDS3660	ESD laminate, square edge	1 ¼	32	60	1524	36	914	67	30.4
WDS3672	ESD laminate, square edge	1 ¼	32	72	1829	36	914	80	36.3
WDS3696	ESD laminate, square edge	1 ¼	32	96	2438	36	914	108	49.0
WDS4248	ESD laminate, square edge	1 ¼	32	48	1219	42	1067	63	28.6
WDS4260	ESD laminate, square edge	1 ¼	32	60	1524	42	1067	78	35.4
WDS4272	ESD laminate, square edge	1 ¼	32	72	1829	42	1067	93	42.2
WDS4296	ESD laminate, square edge	1 ¼	32	96	2438	42	1067	126	57.2
WDS4848	ESD laminate, square edge	1 ¼	32	48	1219	48	1219	72	32.7
WDS4860	ESD laminate, square edge	1 ¼	32	60	1524	48	1219	89	40.4
WDS4872	ESD laminate, square edge	1 ¼	32	72	1829	48	1219	107	48.5
WDS4896	ESD laminate, square edge	1 ¼	32	96	2438	48	1219	144	65.3

Rev 10/20/25

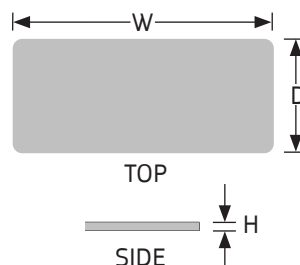
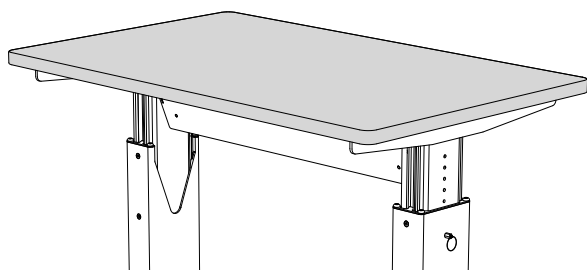

WORK SURFACES, CHEMSURF LAMINATE, T-EDGE

- 1¼" tall high pressure Chemsurf laminate surfaces are made for highly corrosive environments with exceptional chemical and wear resistance.
- Surfaces mount to WorkTable Bases or 4-Legged Tables to construct a height adjustable table.
- Surfaces have a matching vinyl T-edge around the full perimeter (with 1" radius corners).
- 30" deep Work Surfaces do not accept surface mounted accessories deeper than 12".
- 36" deep Work Surfaces do not accept surface mounted accessories deeper than 15".
- 42" deep Work Surfaces do not accept surface mounted accessories deeper than 18".
- 48" deep Work Surfaces do not accept surface mounted accessories deeper than 21".
- Load capacity 500 lbs. evenly distributed.

How to Specify

Step 1. Product Number

WCT Chemsurf Laminate, T-Edge

Step 2. Depth

30 30" deep 36 36" deep 42 42" deep
48 48" deep

Step 3. Width

24 24" wide 30 30" wide 36 36" wide
48 48" wide 60 60" wide 72 72" wide
96 96" wide

Step 4. Chemsurf Laminate Color Code

CBK Black
CGL Grey Light
CNW Neutral White

Product Number	Description	Height		Width		Depth		Weight	
		in.	[mm]	in.	[mm]	in.	[mm]	lb.	[kg]
WCT3048	Chemsurf laminate, t-edge	1 ¼	32	48	1219	30	762	45	20.4
WCT3060	Chemsurf laminate, t-edge	1 ¼	32	60	1524	30	762	56	25.4
WCT3072	Chemsurf laminate, t-edge	1 ¼	32	72	1829	30	762	67	30.4
WCT3096	Chemsurf laminate, t-edge	1 ¼	32	96	2438	30	762	90	40.8
WCT3648	Chemsurf laminate, t-edge	1 ¼	32	48	1219	36	914	54	24.5
WCT3660	Chemsurf laminate, t-edge	1 ¼	32	60	1524	36	914	67	30.4
WCT3672	Chemsurf laminate, t-edge	1 ¼	32	72	1829	36	914	80	36.3
WCT3696	Chemsurf laminate, t-edge	1 ¼	32	96	2438	36	914	108	49.0
WCT4248	Chemsurf laminate, t-edge	1 ¼	32	48	1219	42	1067	63	28.6
WCT4260	Chemsurf laminate, t-edge	1 ¼	32	60	1524	42	1067	78	35.4
WCT4272	Chemsurf laminate, t-edge	1 ¼	32	72	1829	42	1067	93	42.2
WCT4296	Chemsurf laminate, t-edge	1 ¼	32	96	2438	42	1067	126	57.2
WCT4848	Chemsurf laminate, t-edge	1 ¼	32	48	1219	48	1219	72	32.7
WCT4860	Chemsurf laminate, t-edge	1 ¼	32	60	1524	48	1219	89	40.4
WCT4872	Chemsurf laminate, t-edge	1 ¼	32	72	1829	48	1219	107	48.5
WCT4896	Chemsurf laminate, t-edge	1 ¼	32	96	2438	48	1219	144	65.3

Rev 09/27/17

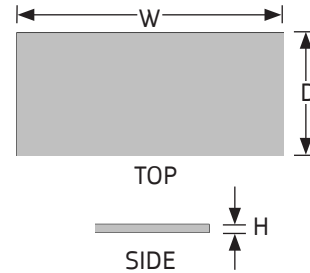
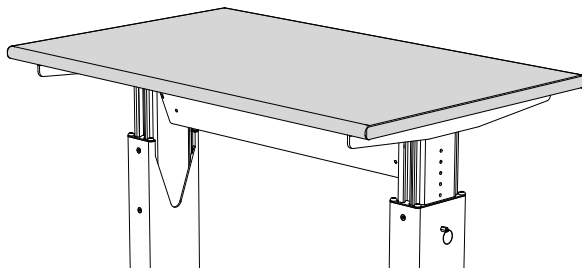

WORK SURFACES, CHEMSURF LAM., SQUARE EDGE

- 1¼" tall high pressure Chemsurf laminate surfaces are made for highly corrosive environments with exceptional chemical and wear resistance.
- Surfaces mount to WorkTable Bases or 4-Legged Tables to construct a height adjustable table.
- Surface have a matching square edge-banding.
- 30" deep Work Surfaces do not accept surface mounted accessories deeper than 12".
- 36" deep Work Surfaces do not accept surface mounted accessories deeper than 15".
- 42" deep Work Surfaces do not accept surface mounted accessories deeper than 18".
- 48" deep Work Surfaces do not accept surface mounted accessories deeper than 21".
- Load capacity 500 lbs. evenly distributed.

How to Specify

Step 1. Product Number

WCS Chemsurf Laminate, Square Edge

Step 2. Depth

30 30" deep 36 36" deep 42 42" deep
48 48" deep

Step 3. Width

24 24" wide 30 30" wide 36 36" wide
48 48" wide 60 60" wide 72 72" wide
96 96" wide

Step 4. Chemsurf Laminate Color Code

CBK Black
CGL Grey Light
CNW Neutral White

Product Number	Description	Height		Width		Depth		Weight	
		in.	[mm]	in.	[mm]	in.	[mm]	lb.	[kg]
WCS3048	Chemsurf laminate, square edge	1 ¼	32	48	1219	30	762	45	20.4
WCS3060	Chemsurf laminate, square edge	1 ¼	32	60	1524	30	762	56	25.4
WCS3072	Chemsurf laminate, square edge	1 ¼	32	72	1829	30	762	67	30.4
WCS3096	Chemsurf laminate, square edge	1 ¼	32	96	2438	30	762	90	40.8
WCS3648	Chemsurf laminate, square edge	1 ¼	32	48	1219	36	914	54	24.5
WCS3660	Chemsurf laminate, square edge	1 ¼	32	60	1524	36	914	67	30.4
WCS3672	Chemsurf laminate, square edge	1 ¼	32	72	1829	36	914	80	36.3
WCS3696	Chemsurf laminate, square edge	1 ¼	32	96	2438	36	914	108	49.0
WCS4248	Chemsurf laminate, square edge	1 ¼	32	48	1219	42	1067	63	28.6
WCS4260	Chemsurf laminate, square edge	1 ¼	32	60	1524	42	1067	78	35.4
WCS4272	Chemsurf laminate, square edge	1 ¼	32	72	1829	42	1067	93	42.2
WCS4296	Chemsurf laminate, square edge	1 ¼	32	96	2438	42	1067	126	57.2
WCS4848	Chemsurf laminate, square edge	1 ¼	32	48	1219	48	1219	72	32.7
WCS4860	Chemsurf laminate, square edge	1 ¼	32	60	1524	48	1219	89	40.4
WCS4872	Chemsurf laminate, square edge	1 ¼	32	72	1829	48	1219	107	48.5
WCS4896	Chemsurf laminate, square edge	1 ¼	32	96	2438	48	1219	144	65.3

Rev 10/20/25

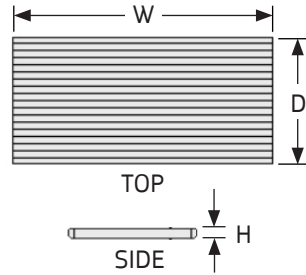
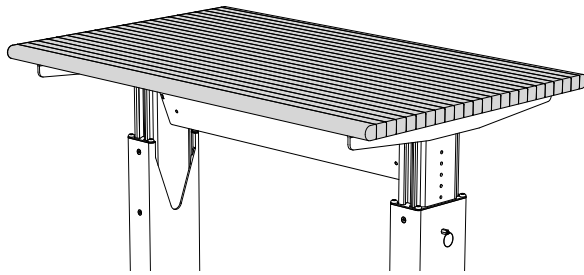

WORK SURFACES, HARDWOOD, 1¼" FULL-RADIUS EDGE

- 1¼" tall Hardwood Surfaces mount to WorkTable or 4-Legged Table Bases only.
- Surfaces consist of kiln-dried hardwood strips that are face glued, sanded smooth and finished with a two coat catalyzed varnish.
- Surfaces have a full-radius front and back edges with square side edges.
- 30" deep Work Surfaces do not accept surface mounted accessories deeper than 12".
- 36" deep Work Surfaces do not accept surface mounted accessories deeper than 15".
- 42" deep Work Surfaces do not accept surface mounted accessories deeper than 18".
- 48" deep Work Surfaces do not accept surface mounted accessories deeper than 21".
- Load capacity 500 lbs. evenly distributed.

How to Specify

Step 1. Product Number

WMR Work Surface, Hardwood, 1¼"

Step 2. Depth

30 30" deep 36 36" deep 42 42" deep
48 48" deep

Step 3. Width

48 48" wide 60 60" wide 72 72" wide
96 96" wide

Step 4. Color Code

CC Hardwood

Product Number	Description	Height		Width		Depth		Weight	
		in.	[mm]	in.	[mm]	in.	[mm]	lb.	[kg]
WMR3048CC	Hardwood, 1¼"	1 ¼	32	48	1219	30	762	50	22.7
WMR3060CC	Hardwood, 1¼"	1 ¼	32	60	1524	30	762	63	28.6
WMR3072CC	Hardwood, 1¼"	1 ¼	32	72	1829	30	762	75	34.0
WMR3096CC	Hardwood, 1¼"	1 ¼	32	96	2438	30	762	100	45.4
WMR3648CC	Hardwood, 1¼"	1 ¼	32	48	1219	36	914	60	27.2
WMR3660CC	Hardwood, 1¼"	1 ¼	32	60	1524	36	914	75	34.0
WMR3672CC	Hardwood, 1¼"	1 ¼	32	72	1829	36	914	90	40.8
WMR3696CC	Hardwood, 1¼"	1 ¼	32	96	2438	36	914	120	54.4
WMR4248CC	Hardwood, 1¼"	1 ¼	32	48	1219	42	1067	70	31.8
WMR4260CC	Hardwood, 1¼"	1 ¼	32	60	1524	42	1067	88	39.9
WMR4272CC	Hardwood, 1¼"	1 ¼	32	72	1829	42	1067	105	47.6
WMR4296CC	Hardwood, 1¼"	1 ¼	32	96	2438	42	1067	140	63.5
WMR4848CC	Hardwood, 1¼"	1 ¼	32	48	1219	48	1219	80	36.3
WMR4860CC	Hardwood, 1¼"	1 ¼	32	60	1524	48	1219	100	45.4
WMR4872CC	Hardwood, 1¼"	1 ¼	32	72	1829	48	1219	120	54.4
WMR4896CC	Hardwood, 1¼"	1 ¼	32	96	2438	48	1219	160	72.6

Rev 09/27/24

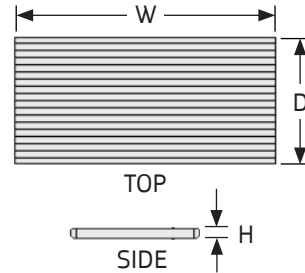
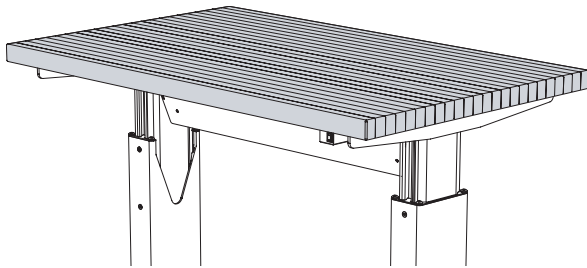

WORK SURFACES, HARDWOOD, 1 3/4" SQUARE EDGE

- 1 3/4" tall Hardwood Surfaces mount to WorkTable or 4-Legged Table Bases only.
- Surfaces consist of kiln-dried hardwood strips that are face glued, sanded smooth and finished with a two coat catalyzed varnish.
- Surfaces have a square-edged front, back and sides.
- 30" deep Work Surfaces do not accept surface mounted accessories deeper than 12".
- 36" deep Work Surfaces do not accept surface mounted accessories deeper than 15".
- 42" deep Work Surfaces do not accept surface mounted accessories deeper than 18".
- 48" deep Work Surfaces do not accept surface mounted accessories deeper than 21".
- Load capacity 500 lbs. evenly distributed.

How to Specify

Step 1. Product Number

WHS Work Surface, Hardwood, 1 3/4"

Step 2. Depth

30 30" deep 36 36" deep 42 42" deep
48 48" deep

Step 3. Width

48 48" wide 60 60" wide 72 72" wide
96 96" wide

Step 4. Color Code

CC Hardwood

Product Number	Description	Height		Width		Depth		Weight	
		in.	[mm]	in.	[mm]	in.	[mm]	lb.	[kg]
WHS3048CC	Hardwood, 1 3/4"	1 3/4	44	48	1219	30	762	70	31.8
WHS3060CC	Hardwood, 1 3/4"	1 3/4	44	60	1524	30	762	88	39.9
WHS3072CC	Hardwood, 1 3/4"	1 3/4	44	72	1829	30	762	105	47.6
WHS3096CC	Hardwood, 1 3/4"	1 3/4	44	96	2438	30	762	140	63.5
WHS3648CC	Hardwood, 1 3/4"	1 3/4	44	48	1219	36	914	84	38.1
WHS3660CC	Hardwood, 1 3/4"	1 3/4	44	60	1524	36	914	105	47.6
WHS3672CC	Hardwood, 1 3/4"	1 3/4	44	72	1829	36	914	126	57.2
WHS3696CC	Hardwood, 1 3/4"	1 3/4	44	96	2438	36	914	168	76.2
WHS4248CC	Hardwood, 1 3/4"	1 3/4	44	48	1219	42	1067	98	44.5
WHS4260CC	Hardwood, 1 3/4"	1 3/4	44	60	1524	42	1067	123	55.8
WHS4272CC	Hardwood, 1 3/4"	1 3/4	44	72	1829	42	1067	147	66.7
WHS4296CC	Hardwood, 1 3/4"	1 3/4	44	96	2438	42	1067	196	88.9
WHS4848CC	Hardwood, 1 3/4"	1 3/4	44	48	1219	48	1219	112	50.8
WHS4860CC	Hardwood, 1 3/4"	1 3/4	44	60	1524	48	1219	140	63.5
WHS4872CC	Hardwood, 1 3/4"	1 3/4	44	72	1829	48	1219	168	76.2
WHS4896CC	Hardwood, 1 3/4"	1 3/4	32	96	2438	48	1219	224	101.6

Rev 09/27/24

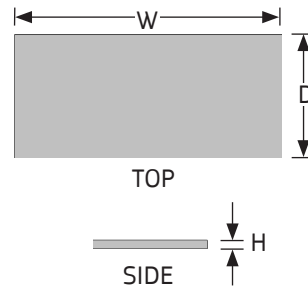
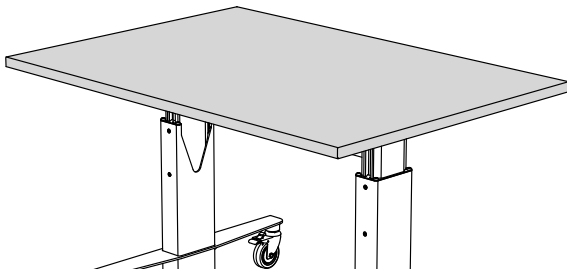

WORK SURFACES, STAINLESS STEEL

- Provides durable work surface for areas where high abrasion, chemical resistance and sterilization are required.
- Surfaces mount to WorkTable or 4-Legged Table Bases only.
- Surfaces are manufactured using 16 gauge stainless steel with a #4 brush finish.
- Surface is constructed of a stainless steel "cap" (tops and sides are formed from one sheet of steel with welded corners) assembled to a core which is laminated with backer material. The joint between the cap and core is sealed around the full perimeter.
- Load capacity is 500 lbs. evenly distributed.

How to Specify

Step 1. Product Number

WSC Work Surface, Stainless Steel

Step 2. Depth

42 42" deep 48 48" deep

Step 3. Width

48 48" wide 60 60" wide 72 72" wide
96 96" wide

Product Number	Description	Height		Width		Depth		Weight	
		in.	[mm]	in.	[mm]	in.	[mm]	lb.	[kg]
WSC4248	Stainless steel	1 1/8	29	48	1219	42	1067	103	46.7
WSC4260	Stainless steel	1 1/8	29	60	1524	42	1067	128	58.1
WSC4272	Stainless steel	1 1/8	29	72	1829	42	1067	154	69.9
WSC4296	Stainless steel	1 1/8	29	96	2438	42	1067	205	93.0
WSC4848	Stainless steel	1 1/8	29	48	1219	48	1219	117	53.1
WSC4860	Stainless steel	1 1/8	29	60	1524	48	1219	147	66.7
WSC4872	Stainless steel	1 1/8	29	72	1829	48	1219	176	79.8
WSC4896	Stainless steel	1 1/8	29	96	2438	48	1219	235	106.6

Rev 02/12/18

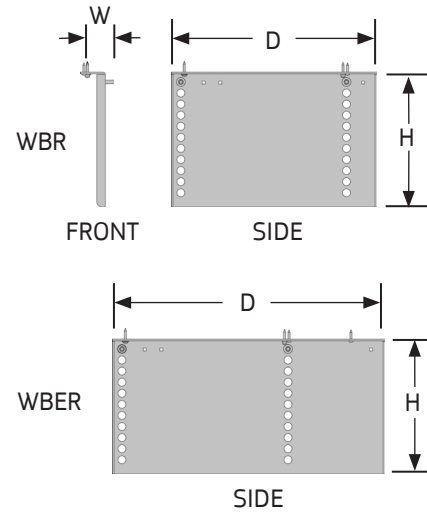
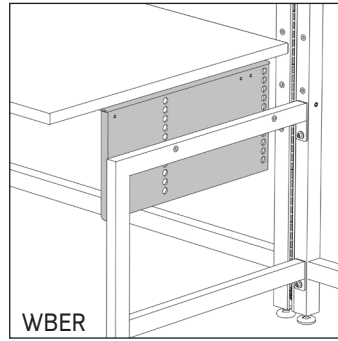
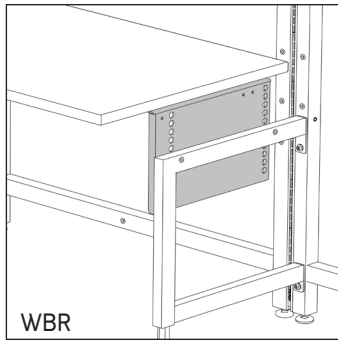

SURFACE B SUPPORT BRACKETS

- Brackets provide manual height adjustable support for Ultra or Work Surfaces mounted to Ultra Leg Supports.
- Brackets allow for surface heights to be adjusted in 1" increments. Height to the top of the support bracket ranges from 25⁷/₈" to 35⁷/₈" when used with Ultra Legs (UL25**) and from 30⁷/₈" to 40⁷/₈" when used with Ultra Legs (UL30**).
- Extended brackets are for use with 36" deep surfaces, while the 18⁵/₈" deep brackets are for use with 24" and 30" deep surfaces.

NOTES

- » 72" and 96" wide frame-mounted surfaces must be supported in the center by Surface Cantilever Supports. Specify one 18" cantilever per 24" and 30" deep surface and one 24" cantilever per 36" deep surface.

How to Specify

Step 1. Product Number

- WBL10** B Support Bracket, left
- WBR10** B Support Bracket, right
- WBEL10** B Support Bracket, extended, left
- WBER10** B Support Bracket, extended, right

Step 2. Paint Color Code

STANDARD

- AW** Arctic White
- AS** Argent Silver
- BK** Black
- BT** Black Texture
- GL** Grey Light Smooth
- GT** Grey Light Texture
- NW** Neutral White
- ST** Sand Texture

Product Number	Description	Height		Width		Depth		Weight	
		in.	[mm]	in.	[mm]	in.	[mm]	lb.	[kg]
WBL10	Bracket, left	12 ¼	311	2 ¼	57	18 5/8	473	12	5.4
WBR10	Bracket, right	12 ¼	311	2 ¼	57	18 5/8	473	12	5.4
WBEL10	Bracket, extended, left	12 ¼	311	2 ¼	57	24 5/8	625	16	7.3
WBER10	Bracket, extended, right	12 ¼	311	2 ¼	57	24 5/8	625	16	7.3

Rev 10/01/19

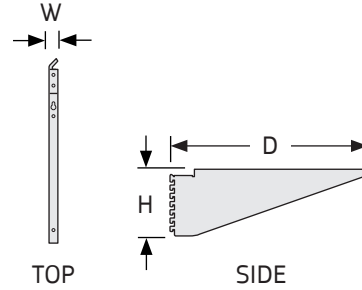
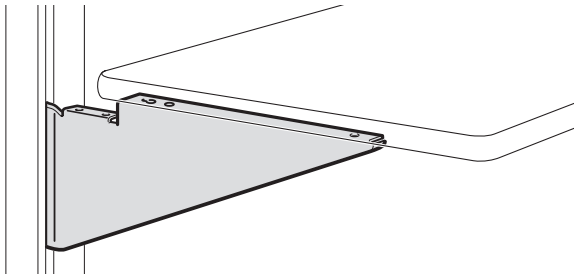

SURFACE CANTILEVER SUPPORTS

- Cantilevers provide manual height adjustable support for 24" and 30" deep Ultra or Work Surfaces mounted to UltraFrames or Panels.
- Cantilevers have a cut-out at the rear allowing for the pass through of cords and cables.

NOTES

- » Use 24" supports with 24" and 30" deep surfaces; 36" deep surfaces require Extended Surface B Support Brackets; see page 4.31.
- » 72" and 96" wide frame-mounted surfaces must be supported in the center by Surface Cantilever Supports. Specify one 18" cantilever per 24" and 30" deep surface and one 24" cantilever per 36" deep surface.

How to Specify

Step 1. Product Number

- WSL Surface Cantilever Support, Left
- WSR Surface Cantilever Support, Right

Step 3. Depth

18 18" deep 24 24" deep

Step 3. Paint Color Code

STANDARD

- AW Arctic White
- AS Argent Silver
- BK Black
- BT Black Texture
- GL Grey Light Smooth
- GT Grey Light Texture
- NW Neutral White
- ST Sand Texture

Product Number	Description	Height		Width		Depth		Weight	
		in.	[mm]	in.	[mm]	in.	[mm]	lb.	[kg]
WSL18	Support, left	8 ½	216	1 ¼	32	18	457	4	1.8
WSR18	Support, right	8 ½	216	1 ¼	32	18	457	4	1.8
WSL24	Support, left	10 ½	267	1 ¼	32	23	584	5	2.3
WSR24	Support, right	10 ½	267	1 ¼	32	23	584	5	2.3

Rev 04/01/19

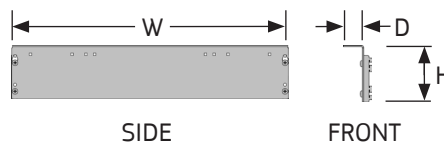
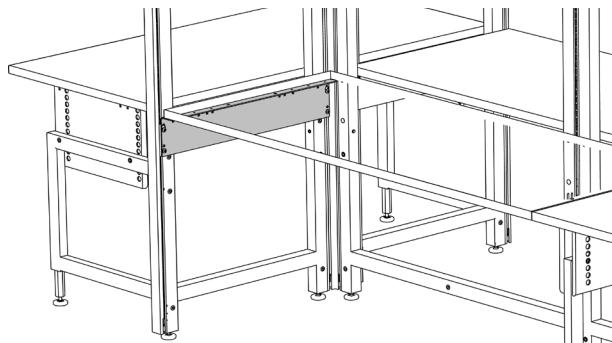

FRAME-MOUNT SURFACE SUPPORTS

- Supports mount to return UltraFrames and Panels providing rigid support for the left and right edges of Ultra or Standard Surfaces.
- Brackets are vertically adjustable in 1" increments.
- Frame-Mount Surface Supports are sold individually and are non-handed for surface depths of 30" and greater.
- Brackets have two hanger clip mounting positions to accommodate both standard and Lab Height Modules.

How to Specify

Step 1. Product Number

- WSB** Frame-Mount Support, Non-Handed
- WSBL** Frame-Mount Support, Left
- WSBR** Frame-Mount Support, Right

Step 2. Depth (Non-Handed only)

- 24** 24" deep **30** 30" deep **36** 36" deep

Step 3. Depth (WSBL and WSBR only)

- 24** 24" deep

Step 4. Paint Color Code

STANDARD

- AW** Arctic White **GL** Grey Light Smooth
- AS** Argent Silver **GT** Grey Light Texture
- BK** Black **NW** Neutral White
- BT** Black Texture **ST** Sand Texture

Product Number	Description	Height		Width		Depth		Weight	
		in.	[mm]	in.	[mm]	in.	[mm]	lb.	[kg]
WSB30	Non-handed	5 ¾	146	30	762	2	51	10	4.5
WSB36	Non-handed	5 ¾	146	36	914	2	51	12	5.4
WSBL24	Left	5 ¾	146	24	610	2	51	8	3.6
WSBR24	Right	5 ¾	146	24	610	2	51	8	3.6

Rev 04/01/19

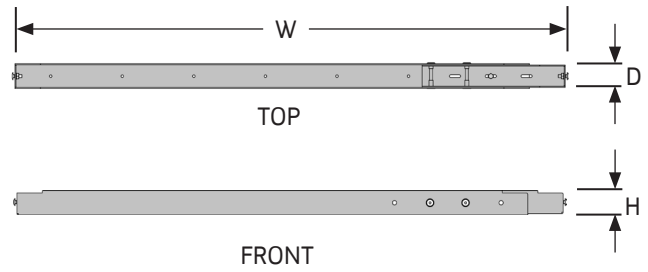
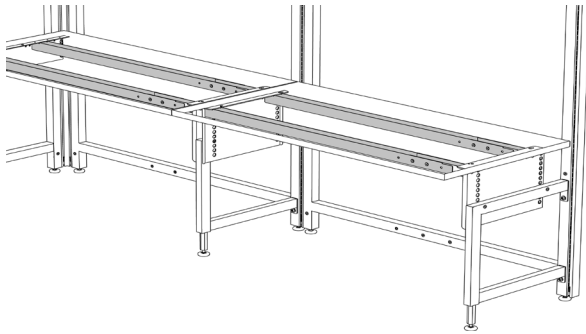

SURFACE REINFORCEMENT BARS

- Sold in pairs, Surface Reinforcement Bars provide horizontal support under surfaces for increased rigidity.
- Bars mount to Surface B Supports, Lab Height B Supports or Frame-Mount Surface Supports.
- Bars adjust over a 6" range to accommodate inboard and outboard Ultra Leg clearance.
- Finish is Black.

NOTES

» Reinforcement Bars cannot be used with Cantilever Brackets.

How to Specify

Step 1. Product Number

WRB Surface Reinforcement Bars, Pair

Step 2. Width

48 48" wide 60 60" wide 72 72" wide

Step 3. Paint Color Code

BK Black

Product Number	Description	Height		Width		Depth		Weight	
		in.	[mm]	in.	[mm]	in.	[mm]	lb.	[kg]
WRB48BK	Reinforcement bar, pair	2	51	49 ½	1257	2	51	15	6.8
WRB60BK	Reinforcement bar, pair	2	51	61 ½	1562	2	51	18	8.2
WRB72BK	Reinforcement bar, pair	2	51	73 ½	1867	2	51	21	9.5

Rev 07/31/14

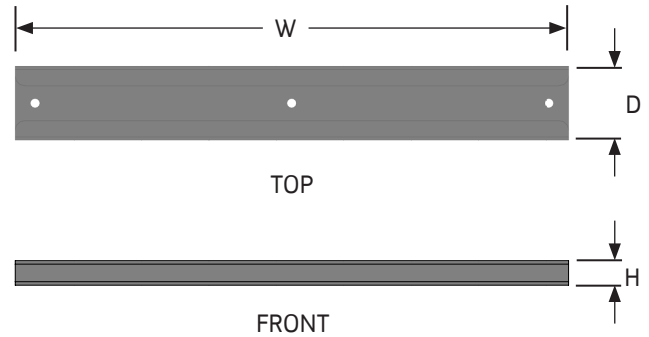
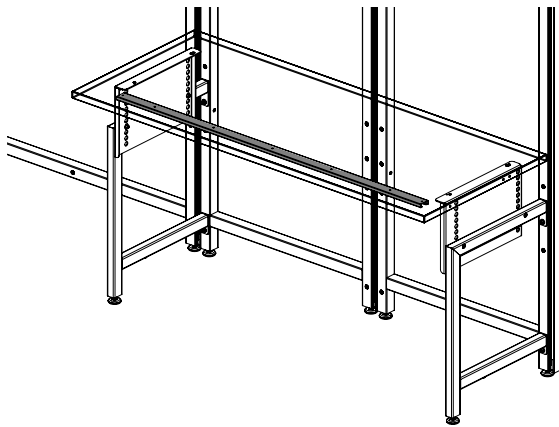

SURFACE SUPPORT BAR

- Sold individually, the Surface Support Bar provides horizontal support under standard surfaces for added support and weight load capacity up to 500lbs., evenly distributed.
- Support Bars can be used with surfaces supported by Cantilever Brackets, Work Surface B-Supports, Table Bases, and ErgoStats.
- Finish is Black.

How to Specify

Step 1. Product Number

SSB Surface Support Bar

Step 2. Width

48 48" wide 60 60" wide
 72 72" wide 96 96" wide

Step 3. Paint Color Code

BK Black

Product Number	Description	Height		Width		Depth		Weight	
		in.	[mm]	in.	[mm]	in.	[mm]	lb.	[kg]
SSB48BK	Support Bar	5/8	16	38	965	1 7/8	48	2	1
SSB60BK	Support Bar	5/8	16	50	1270	1 7/8	48	3	1.4
SSB72BK	Support Bar	5/8	16	62	1575	1 7/8	48	4	1.8
SSB96BK	Support Bar	5/8	16	86	2184	1 7/8	48	5	2.5

Rev 02/18/25

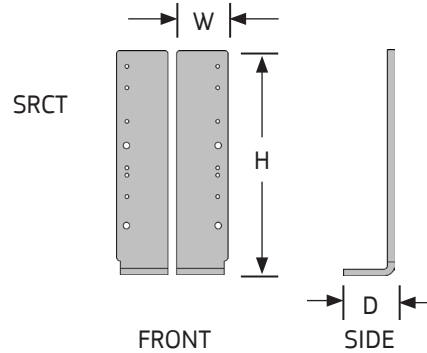
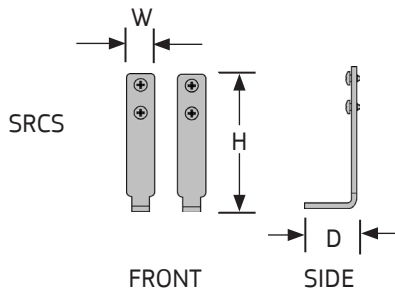
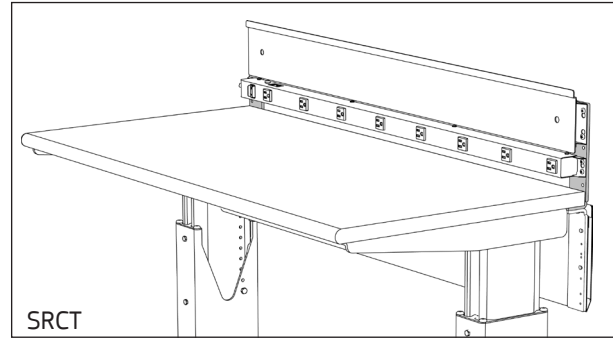
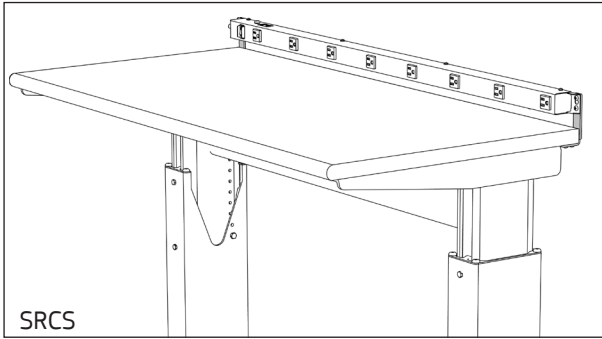

SURFACE ACCESSORY BRACKETS

- Brackets provide mounting locations for accessories above or below the surface.
- Short Surface Accessory Brackets are non-handed and mount Electric Plug Strips approximately 1” above the surface, or can be flipped over to mount plug strips 2½” below the surface.
- Tall Surface Accessory Brackets are handed and can be used to mount Dispensing Rails, Bin Rails, Slatwall Rails, Electric Plug Strips or Air Strips above the surface.
- The tall brackets can also be flipped over and mounted to the underside of the surface to support Frame-mount Cable Trays or Electric Plug Strips.
- Brackets are sold in pairs and mount to surfaces with wood screws.
- Finish is Black.

NOTES

- » Two pairs of Tall Surface Accessory Brackets are shown in the image above.
- » Ultra Surfaces, Standard Surfaces and Work Surfaces are not pre-drilled for Surface Accessory Brackets.

How to Specify

Step 1. Product Number

- SRCS Surface Accessory Bracket, Short
- SRCT Surface Accessory Bracket, Tall

Step 2. Paint Color Code

- BK Black

Product Number	Description	Height		Width		Depth		Weight	
		in.	[mm]	in.	[mm]	in.	[mm]	lb.	[kg]
SRCSBK	Short bracket	4	102	¾	19	1 ½	38	1	0.5
SRCTBK	Tall bracket	8 ¼	210	2	51	1 ½	38	3	1.4

Rev 07/31/14

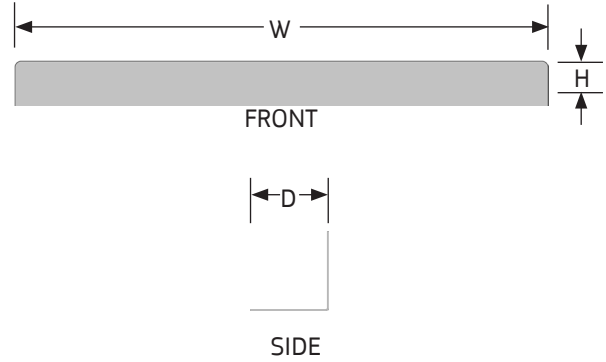
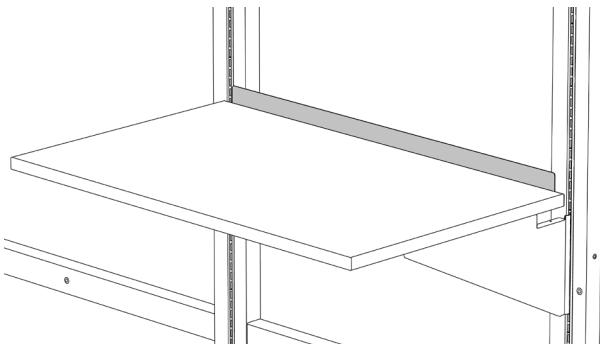

SURFACE BACK STOPS

- Surface Back Stops prevent equipment or small parts from falling off the back edge of surfaces.
- Steel stops provide a 1¾" raised edge above the back of 1¼" high surfaces.

NOTES

- » Can be used together with Universal Cable Trays which are sold separately; see page 9.5.

How to Specify

Step 1. Product Number

BS Surface Back Stop

Step 2. Width

24 24" wide 30 30" wide 36 36" wide
 48 48" wide 60 60" wide 72 72" wide

Step 3. Paint Color Code

STANDARD

AW Arctic White	GL Grey Light Smooth
AS Argent Silver	GT Grey Light Texture
BK Black	NW Neutral White
BT Black Texture	ST Sand Texture

Product Number	Description	Height		Width		Depth		Weight	
		in.	[mm]	in.	[mm]	in.	[mm]	lb.	[kg]
BS24	Back stop	3	76	21 ½	546	3	76	3	1.4
BS30	Back stop	3	76	27 ½	699	3	76	4	1.6
BS36	Back stop	3	76	33 ½	851	3	76	5	2.3
BS48	Back stop	3	76	45 ½	1156	3	76	6	2.7
BS60	Back stop	3	76	57 ½	1461	3	76	7	3.2
BS72	Back stop	3	76	69 ½	1765	3	76	8	3.6

Rev 04/01/19

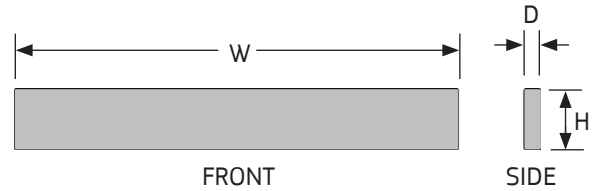
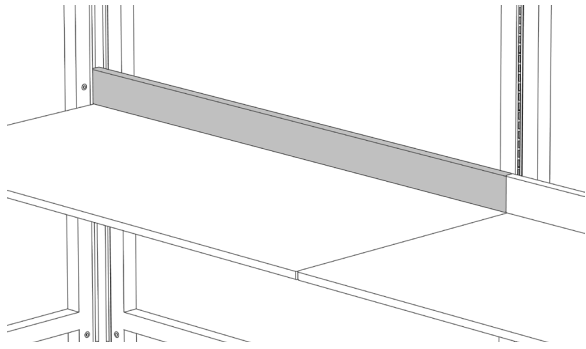

PHENOLIC BACKSPLASHES

- 4" high solid Phenolic Backsplashes have smooth 1/8" radius corners and edges.
- Phenolic resin material is specifically manufactured for highly corrosive environments and provides exceptional chemical and wear resistance. Contact the factory for detailed chemical resistance testing data.
- Finish is Black.

NOTES

- » Mounting hardware is not included. Adhesive or thru-bolting to the horizontal surface is recommended.

How to Specify

Step 1. Product Number

BSP4 Phenolic Backsplash

Step 2. Width

24 24" wide 30 30" wide 36 36" wide
 48 48" wide 60 60" wide 72 72" wide
 96 96" wide

Step 3. Paint Color Code

BK Black

Product Number	Description	Height		Width		Depth		Weight	
		in.	[mm]	in.	[mm]	in.	[mm]	lb.	[kg]
BSP424BK	Backsplash	4	102	24	610	1	25	5	2.3
BSP430BK	Backsplash	4	102	30	762	1	25	6	2.7
PSP436BK	Backsplash	4	102	36	914	1	25	7	3.2
BSP448BK	Backsplash	4	102	48	1219	1	25	10	4.5
BSP460BK	Backsplash	4	102	60	1524	1	25	12	5.4
BSP472BK	Backsplash	4	102	72	1829	1	25	14	6.4
BSP496BK	Backsplash	4	102	96	2438	1	25	19	8.6

Rev 03/20/12

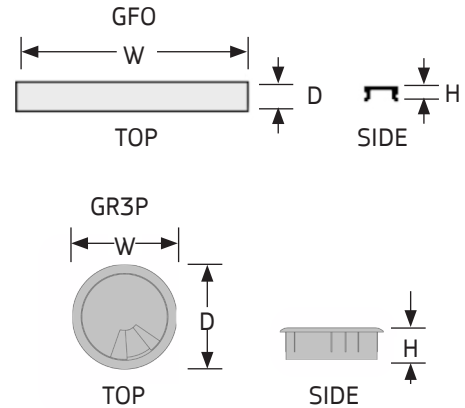
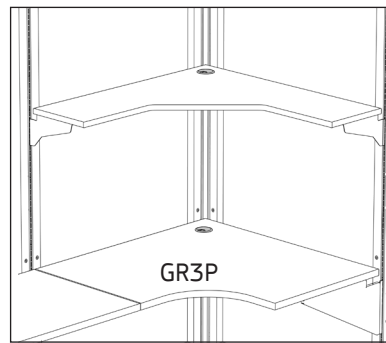
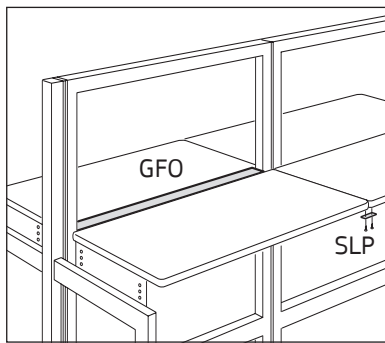

SURFACE GAP FILLERS AND LEVELING PLATES

Surface Gap Fillers

- Surface Gap Fillers cover the gaps between back-to-back surfaces mounted on UltraFrames.
- Painted steel fillers have a spring form fit and work with all surface types.
- Finish must be specified.

Surface Leveling Plates

- 10 gauge steel plates fasten to the underside of adjacent surfaces providing additional support and alignment for the front edges.
- Finish is Black.

Grommets

- Plastic wiring grommet provides power and data cable management through the work surface.
- Grommet has removable cap with adjustable opening for desired cable capacity.
- Field installed using a 3-1/8" (79mm) hole saw.
- Finish is Black.

NOTES

- » Surface Leveling Plates are not to be used to attach Surface Peninsulas to adjacent surfaces.

How to Specify

Step 1. Product Number

- GFO Surface Gap Filler
- SLP Surface Leveling Plate
- BR3P Grommet

Step 2. Width (Gap Filler only)

- 30 30" wide 36 36" wide 48 48" wide
- 60 60" wide

Step 3. Paint Color Code (Gap Filler only)

STANDARD

- AW Arctic White
- AS Argent Silver
- BK Black
- BT Black Texture
- GL Grey Light Smooth
- GT Grey Light Texture
- NW Neutral White
- ST Sand Texture

Step 4. Color (Leveling Plate, Grommets only)

- BK Black

Product Number	Description	Height		Width		Depth		Weight	
		in.	[mm]	in.	[mm]	in.	[mm]	lb.	[kg]
GFO30	Gap filler	1	25	26	660	5 1/4	133	2	0.9
GFO36	Gap filler	1	25	32	813	5 1/4	133	2	0.9
GFO48	Gap filler	1	25	44	1118	5 1/4	133	3	1.4
GFO60	Gap filler	1	25	55	1397	5 1/4	133	4	1.8
SLPBK	Leveling plate	1/8	3	3	76	3/4	19	1/4	0.1
GR3PBK	Grommet	1	25	3	76	3	76	1	0.5

Rev 04/01/19

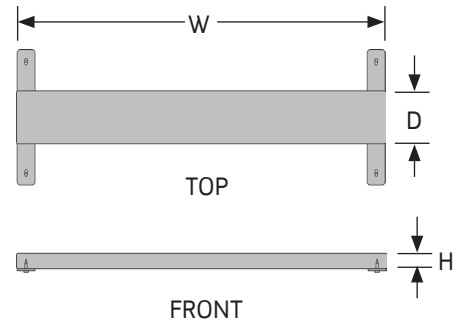
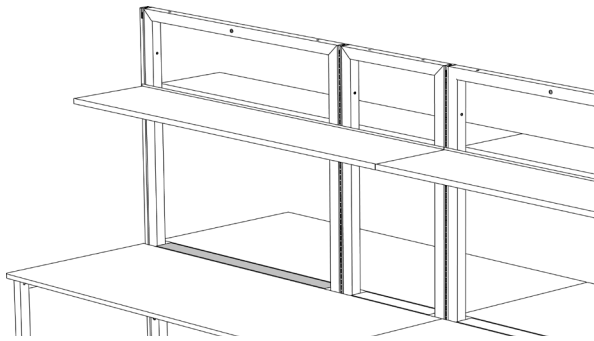

PHENOLIC GAP FILLERS

- 1" high solid Phenolic Resin Gap Fillers cover the gaps between back-to-back surfaces mounted on UltraFrames.
- Fillers have smooth 1/8" radius corners and edges.
- Phenolic resin material is specifically manufactured for highly corrosive environments and provides exceptional chemical and wear resistance. Contact the factory for detailed chemical resistance testing data.
- Finish is Black.

How to Specify

Step 1. Product Number

GFP Phenolic Gap Filler

Step 2. Width

24 24" wide 30 30" wide 36 36" wide
 48 48" wide 60 60" wide

Step 3. Paint Color Code

BK Black

Product Number	Description	Height		Width		Depth		Weight	
		in.	[mm]	in.	[mm]	in.	[mm]	lb.	[kg]
GFP24BK	Gap filler	1	25	18	457	3 1/2	89	3	1.4
GFP30BK	Gap filler	1	25	24	610	3 1/2	89	4	1.8
GFP36BK	Gap filler	1	25	30	762	3 1/2	89	5	2.3
GFP48BK	Gap filler	1	25	42	1067	3 1/2	89	7	3.2
GFP60BK	Gap filler	1	25	54	1372	3 1/2	89	9	4.1

Rev 03/20/12

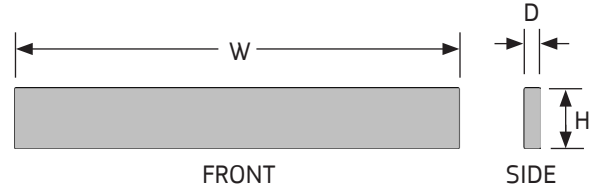
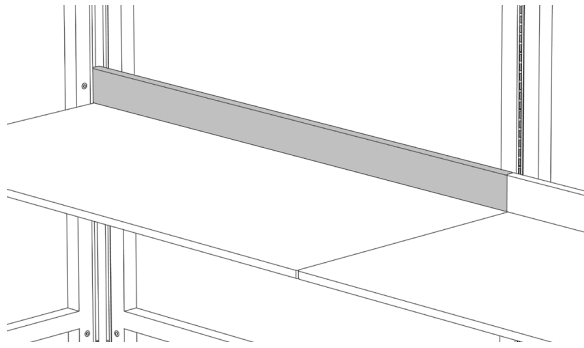

CORIAN BACKSPLASHES

- 4" high solid Corian Backsplashes have smooth 1/8" beveled top front edge. All other edges and corners have a slight break.
- Corian Backsplashes are used in areas where high chemical and wear resistance are required.

NOTES

- » Mounting hardware is not included. A clear silicon adhesive should be used for adherence to the horizontal Corian surface is recommended.

How to Specify

Step 1. Product Number

BSK Corian Backsplash

Step 2. Width

24 24" wide **30** 30" wide **36** 36" wide
48 48" wide **60** 60" wide **72** 72" wide
96 96" wide

Step 3. Corian Color Code

SAE Arista Beige GRD 2 **SDN** Deep Nocturne GRD 3
SAG Arista Gray GRD 2 **SGX** Gray Onyx GRD 4
SBQ Bisque GRD 1 **SMW** Modern White GRD 2

Product Number	Description	Height		Width		Depth		Weight	
		in.	[mm]	in.	[mm]	in.	[mm]	lb.	[kg]
BSK424	Backsplash	4	102	24	610	1.25	32	6	2.5
BSK430	Backsplash	4	102	30	762	1.25	32	7	3.0
BSK436	Backsplash	4	102	36	914	1.25	32	8	3.7
BSK448	Backsplash	4	102	48	1219	1.25	32	11	5.0
BSK460	Backsplash	4	102	60	1524	1.25	32	14	6.2
BSK472	Backsplash	4	102	72	1829	1.25	32	16	7.4
BSK496	Backsplash	4	102	96	2438	1.25	32	22	10

Rev 09/23/25

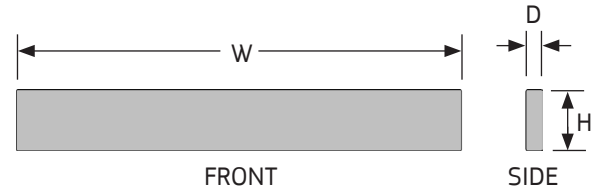
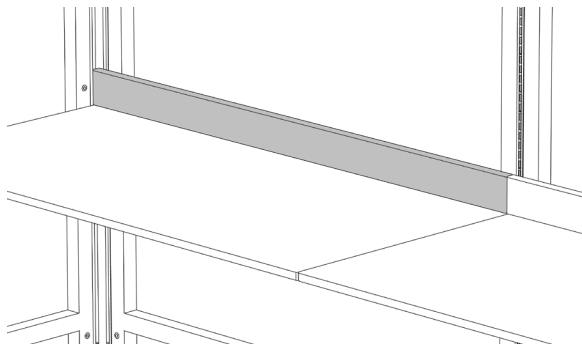

EPOXY BACKSPLASHES

- 4" high solid Epoxy Backsplashes have smooth 1/8" beveled top front edge. All other edges and corners contain a slight break.
- Epoxy resin material is specifically manufactured for highly corrosive environments and provides exceptional chemical and wear resistance. Contact the factory for detailed chemical resistance testing data.
- Finish is Black.

NOTES

- » Mounting hardware is not included. Adhesive or thru-bolting to the horizontal surface is recommended.
- » Other colors available; premium pricing. Consult factory.

How to Specify

Step 1. Product Number

BSE4 Epoxy Backsplash

Step 2. Width

24 24" wide 30 30" wide 36 36" wide
 48 48" wide 60 60" wide 72 72" wide
 96 96" wide

Step 3. Color Code

BK Black

Product Number	Description	Height		Width		Depth		Weight	
		in.	[mm]	in.	[mm]	in.	[mm]	lb.	[kg]
BSE424BK	Epoxy Backsplash	4	102	24	610	1	25	7	3.3
BSE430BK	Epoxy Backsplash	4	102	30	762	1	25	9	4.2
BSE436BK	Epoxy Backsplash	4	102	36	914	1	25	11	5.0
BSE448BK	Epoxy Backsplash	4	102	48	1219	1	25	15	6.7
BSE460BK	Epoxy Backsplash	4	102	60	1524	1	25	18	8.3
BSE472BK	Epoxy Backsplash	4	102	72	1829	1	25	22	10.0
BSE496BK	Epoxy Backsplash	4	102	96	2438	1	25	29	13.3

Rev 05/16/24

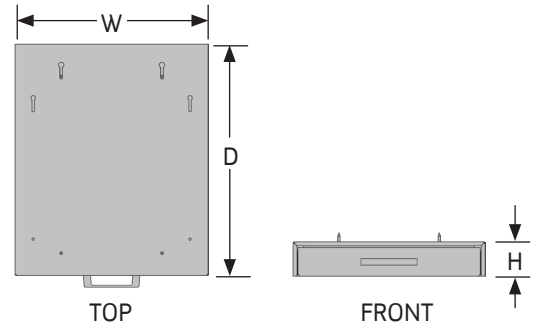
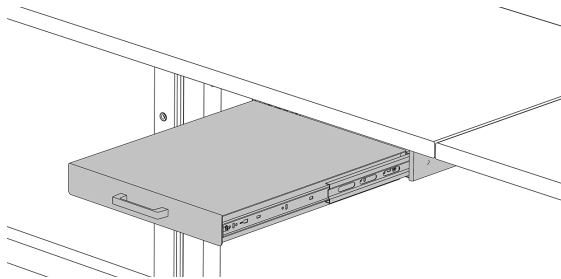

AUXILIARY SURFACE

- Steel platform and housing provides additional work surface space and mounts to surfaces or Storage Accessory Mounting Brackets.
- Surface features 18" full-extension ball-bearing slides with in and out detent.
- Load capacity 35 pounds evenly distributed.

How to Specify

Step 1. Product Number

AWS1518 Auxiliary Surface

Step 2. Paint Color Code

- BK Black
- BT Black Texture
- GL Grey Light Smooth
- GT Grey Light Texture
- NW Neutral White
- ST Sand Texture

Product Number	Description	Height		Width		Depth		Weight	
		in.	[mm]	in.	[mm]	in.	[mm]	lb.	[kg]
AWS1518	Auxiliary surface	2 5/8	67	15	381	18	457	16	7.0

Rev 04/01/19

THIS PAGE LEFT BLANK

