

## Health / Life Science Labs



SYMBIOTE

**WE DESIGN IT. WE PLAN IT. WE GET IT.**



#### **USER-CENTRIC PRODUCT KNOWLEDGE**

We have a deep knowledge of health / life science labs. Our founder began his career with the Herman Miller® Research Corporation and later, the Action Office® team, launching the world's first systems furniture. Subsequently, he led the implementation team, the first product manager for the Health Science Division. We truly understand what people need to be safe, comfortable and productive.

#### **INDUSTRIAL STRENGTH FURNITURE MEETS WORLD-CLASS DESIGN**

From high-tech tables and industrial benches, to modular casegoods and plug/play utilities, our furniture adapts with ease. Visualize your lab in high resolution renderings using industry-leading Configura software. Our dedicated design team supports you from idea to reality, including custom requests.

**E**



**APPLICATIONS**  
Education  
Government  
Healthcare  
Medical  
Pharmacy  
Prep and Pack (shown)  
R&D / Test Labs

#### **HEIGHT ADJUSTABLE TABLES**

Three electric and pin-adjustable models are available in work surface lengths of 48-96 inches. Tables support loads from 750-1,000 pounds, evenly distributed.

#### **ERGOSTAT: OUR HEAVY DUTY, SIT/STAND WORKSTATION**

Available in electric or a pin-adjustable base, ErgoStat has a dynamic lift capacity of 750 pounds. Choose from two travel ranges, 15 and 18 inches, and add a Riser Frame for additional overhead storage and hanging components. The frame and components move up and down with the work surface, for ergonomic flexibility.

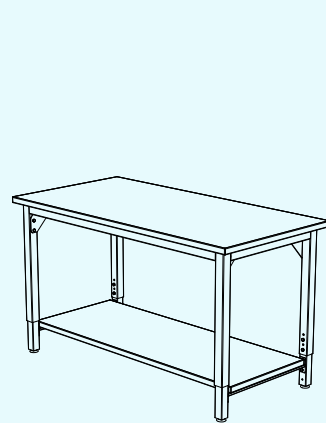

### THE WORKHORSE

4-Legged, pin-adjustable table lifts 1,000 pounds, evenly distributed.

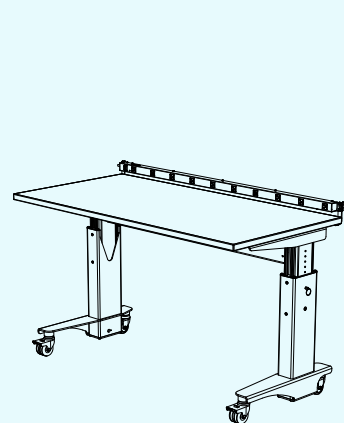

### POWER AND UTILITIES

Electric or pin-adjustable Table Base is available in a 15 or 18-inch travel range and lifts 750 pounds, evenly distributed.

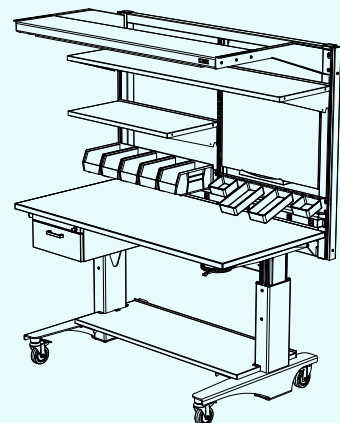

### HOW YOU MOVE

Gain vertical space with a Riser Frame. Bin rails, shelves and other hanging work tools move safely with you as the surface is adjusted up/down.

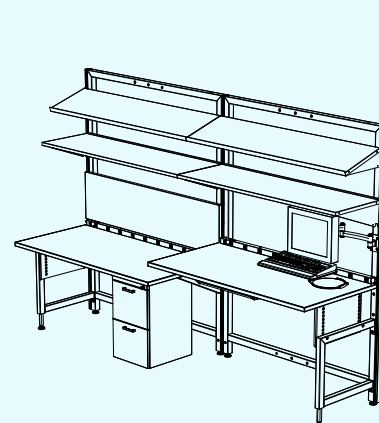

### VERTICAL STORAGE

Taller workstations provide extra overhead storage. Customize it with varied height surfaces and casters for mobility.

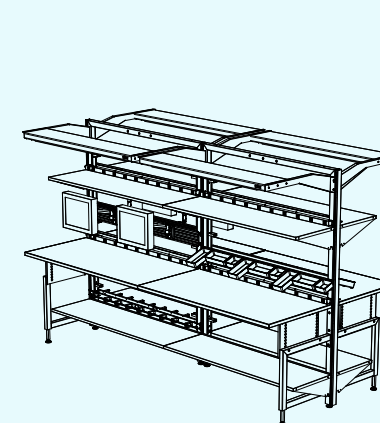

### CONFIGURE BACK-TO-BACK

Double-sided designs save facility space. Slatwalls free up surfaces and organizes tools.

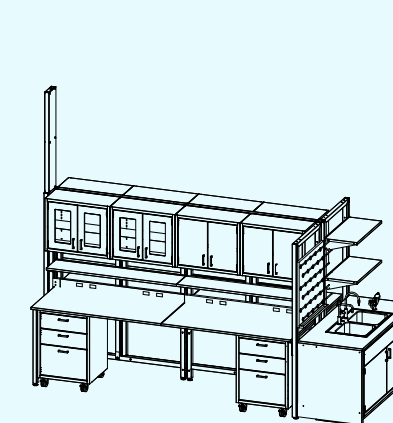

### OPTIONS TO GROW

Drying rack and trough, placed over sink, dries glassware. Vertical utility chase provides plug/play access.



Dispensing rails and subcontainers



Locking casters on frames, tables, base cabinets



Totes/Frame



Drain board



Vertical utility chase

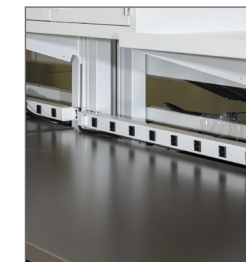

15/20 amp plug strips, Chemsurf and Phenolic surfaces

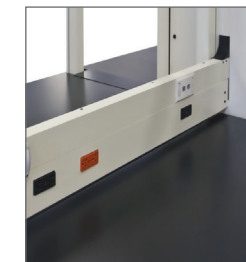

Electrical and data distribution



Fume hood and sink base cabinets



Bins for small parts



Overhead storage with privacy or glass front



Shelving in five styles



LED high output task lighting



Floor cases



Mobile casegoods



Vented cabinets

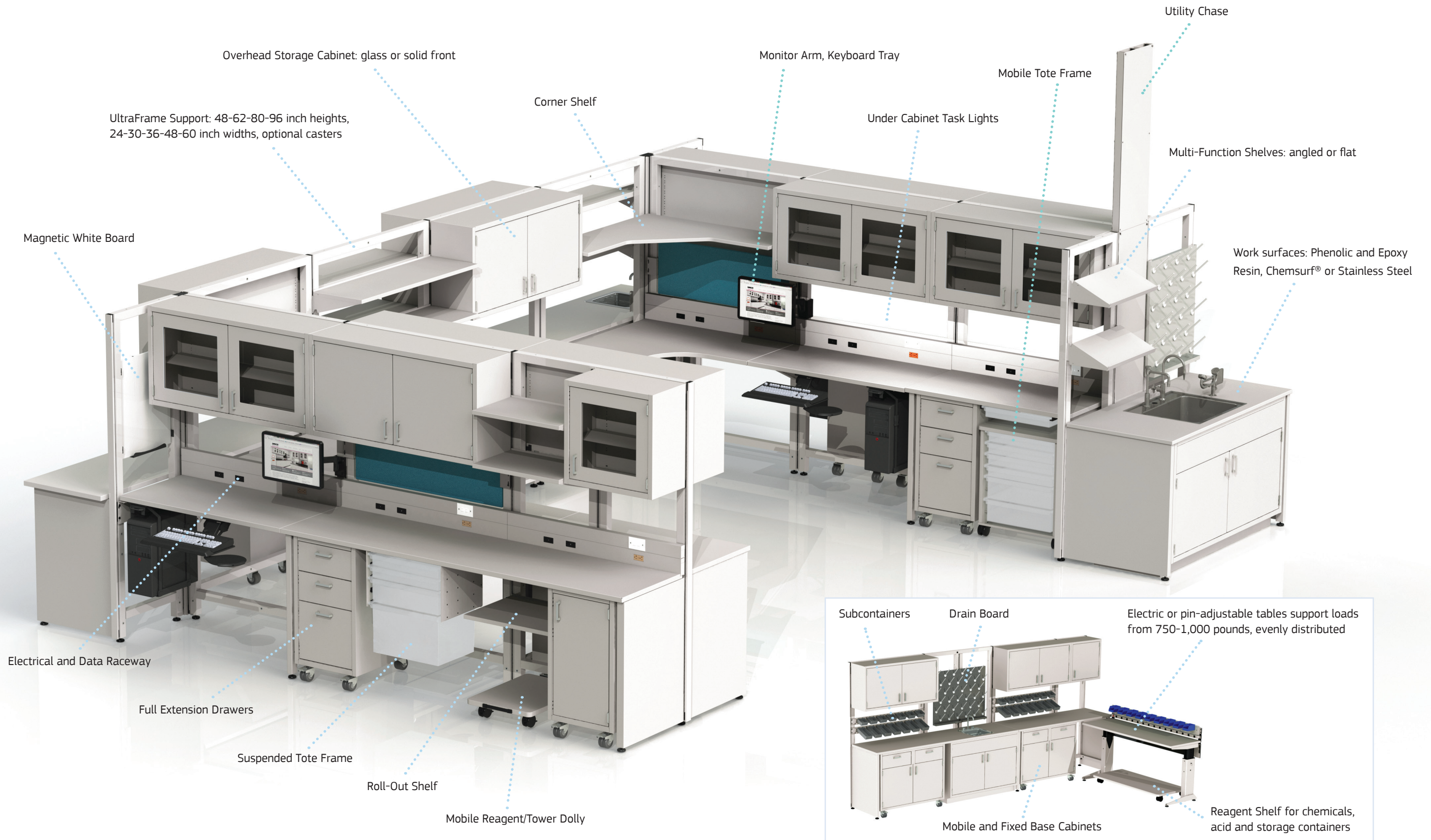

## STRUCTURE

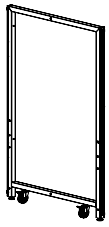

UltraFrame  
Glides / Casters

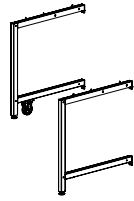

Lab Legs  
Glides / Casters

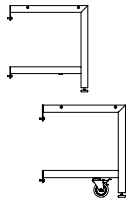

Ultra Legs  
Glides / Combo

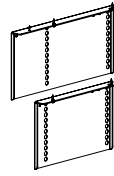

B Support  
Brackets

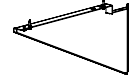

Cantilever  
Brackets

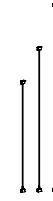

Panel  
Connectors



Reinforcement  
Bars (Surface)

## CABINETS AND CASES

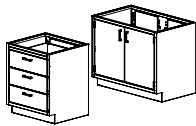

Base Cabinets



Mobile Cabinets

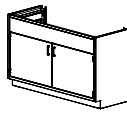

Sink Base Cabinets

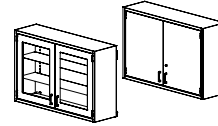

Wall Cases

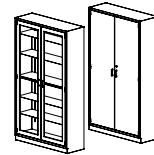

Floor Cases

## STORAGE

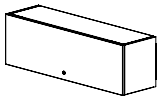

Storage Cabinets

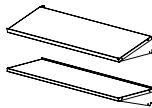

Multi-Function Shelves

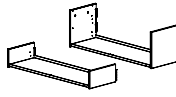

Bookend Shelves

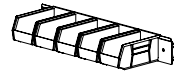

Bin Rail with Bins

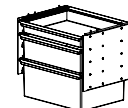

Tote/Frame



Bottle Drawers

## TABLES AND WORKSURFACES

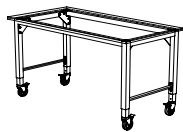

4-Legged Table

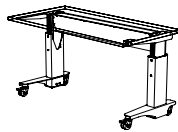
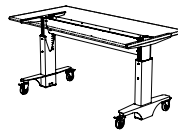
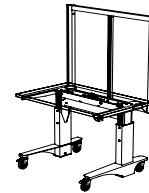

Table Base



WorkTable



ErgoStat

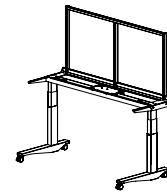

ErgoStat Pro

## LIGHTING AND POWER

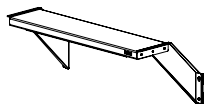

LED Task Light



Magnification Light



Vertical Utility Chase

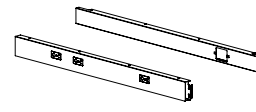

Electrical and Data Distributors



Plug Strips

## ACCESSORIES

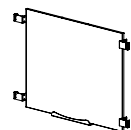

Marker Board

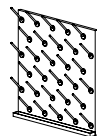

Drain Board

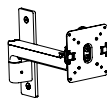

Monitor Arm

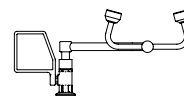

Eyewash Stations

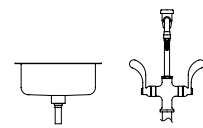

Sinks and Faucets