

LAB PRODUCTS

| | | | |
|--|-------|--|-------|
| Mobile Base Cabinets, Double Drawer & Door..... | 10.2 | Lab Legs | 10.29 |
| Fixed Base Cabinets, Double Drawer & Door..... | 10.3 | Lab Legs, ADA..... | 10.30 |
| Mobile Base Cabinets, Single Drawer & Door..... | 10.4 | Adjacent Brackets | 10.31 |
| Fixed Base Cabinets, Single Drawer & Door..... | 10.5 | Surface Reinforcement Bars..... | 10.32 |
| Suspended Base Cabinets, Drawer/Door..... | 10.6 | Phenolic Lab Surfaces | 10.33 |
| Mobile Base Cabinets, Single Door..... | 10.7 | Epoxy Lab Surfaces..... | 10.34 |
| Fixed Base Cabinets, Single Door..... | 10.8 | Lab Leg Panels..... | 10.35 |
| Mobile Base Cabinets, Double Door..... | 10.9 | Lab Leg Panels, ADA..... | 10.36 |
| Fixed Base Cabinets, Double Door..... | 10.10 | Lab Cabinet Fillers..... | 10.37 |
| Suspended Base Cabinets, Single & Dbl. Door..... | 10.11 | Lab Leg Fillers | 10.39 |
| Fixed Base Cabinets, Open Unit..... | 10.12 | Sloped Top Covers..... | 10.40 |
| Base Cabinets, Sitting Height, Double Drawer | 10.13 | Drain Board, Frame-Mount..... | 10.41 |
| Base Cabinets, Sitting Height, 3-Drawer..... | 10.14 | Drain Board, Wall-Mount..... | 10.42 |
| Suspended Base Cabinets, Drawers | 10.15 | Sink, Undermount..... | 10.43 |
| 4-Legged Table Cabinet Mounting Brackets..... | 10.16 | Sink, Drop-In | 10.44 |
| Base Cabinets, Standing Height 3-Drawer..... | 10.17 | Sink Faucets, Undermount and Drop-In..... | 10.45 |
| Base Cabinets, Standing Height 4-Drawer..... | 10.18 | Eyewash Stations..... | 10.46 |
| Bottle Drawer Cabinets | 10.19 | Ball Valves | 10.47 |
| Sink Base Cabinet, Standard | 10.20 | Vertical Utility Chase, ErgoStat Riser Frame | 10.48 |
| Sink Base Cabinet, ADA, Standard..... | 10.21 | Vertical Utility Chase, UltraFrame..... | 10.49 |
| Sink Base Cabinet, ADA, Door To Floor..... | 10.22 | Ceiling Service Panel, Quick Disconnect..... | 10.50 |
| Wall Cases, Glass Doors | 10.23 | | |
| Wall Cases, Solid Doors..... | 10.24 | | |
| Floor Cases..... | 10.25 | | |
| Wall Strips..... | 10.26 | | |
| Cantilever Brackets | 10.27 | | |
| Lab Height B Supports..... | 10.28 | | |

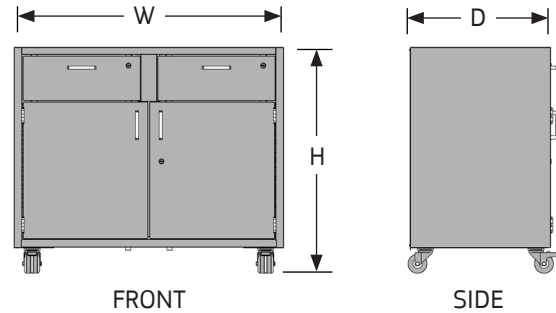

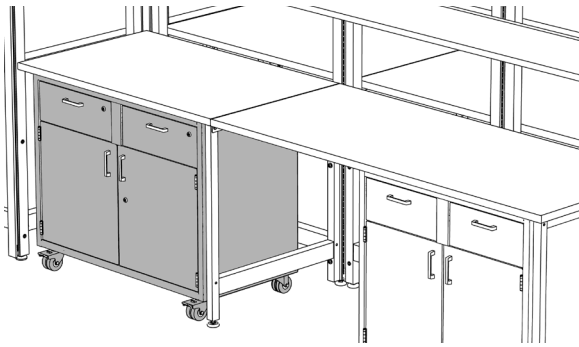

MOBILE BASE CABINETS, DOUBLE DRAWER & DOOR

- Built to SEFA standards, Cabinets are constructed of welded 18 and 20 gauge steel with a chemical resistant epoxy powder coat paint finish.
- Drawers have full-extension ball bearing, plated drawer slides.
- Doors have 5-knuckle stainless steel institutional type hinges.
- Sound deadened doors and drawers have "double pan" construction with a bar pull.
- A removable bottom pan and a single full-depth adjustable shelf is included with each cabinet. Additional shelves available; consult factory.
- Available with or without locks. Locking cabinets with multiple doors/drawers per unit will have the same key number per unit. Individual units will be keyed randomly and differently from the other. Contact factory for other keying options. Available key numbers are LL226 thru LL327.
- Mobile units have a solid steel top and back with two front total lock casters and two rear swivel casters.

NOTES

- » Base Cabinets can be used in conjunction with UltraFrame, Lab Legs and support brackets; see pages 2.2, 10.27-10.29.
- » Recessed pulls available; consult factory.

How to Specify

Step 1. Product Number

LUCB Base Cabinet

Step 2. Height

29 29" high 35 35" high

Step 3. Width

30 30" wide 36 36" wide 42 42" wide
48 48" wide

Step 4. Casters, Drawer/Door, Pull Type

C2DB Casters, Double Drawer and Door

Step 5. Locking/Non-Locking

N Non-Locking L Locking

Step 6. Paint Color Code

BK Black
GL Grey Light Smooth
NW Neutral White

| Product Number | Description | Height | | Width | | Depth | | Weight | |
|----------------|------------------------------|--------|------|-------|------|--------|------|--------|------|
| | | in. | [mm] | in. | [mm] | in. | [mm] | lb. | [kg] |
| LUCB2930C2DBN | Sitting height, non-locking | 29 | 737 | 30 | 762 | 21 7/8 | 556 | 116 | 52.6 |
| LUCB2936C2DBN | Sitting height, non-locking | 29 | 737 | 36 | 914 | 21 7/8 | 556 | 126 | 57.2 |
| LUCB2942C2DBN | Sitting height, non-locking | 29 | 737 | 42 | 1067 | 21 7/8 | 556 | 136 | 61.7 |
| LUCB2948C2DBN | Sitting height, non-locking | 29 | 737 | 48 | 1219 | 21 7/8 | 556 | 151 | 68.5 |
| LUCB3530C2DBN | Standing height, non-locking | 35 | 889 | 30 | 762 | 21 7/8 | 556 | 146 | 66.2 |
| LUCB3536C2DBN | Standing height, non-locking | 35 | 889 | 36 | 914 | 21 7/8 | 556 | 156 | 70.8 |
| LUCB3542C2DBN | Standing height, non-locking | 35 | 889 | 42 | 1067 | 21 7/8 | 556 | 171 | 77.6 |
| LUCB3548C2DBN | Standing height, non-locking | 35 | 889 | 48 | 1219 | 21 7/8 | 556 | 181 | 82.1 |
| LUCB2930C2DBL | Sitting height, locking | 29 | 737 | 30 | 762 | 21 7/8 | 556 | 116 | 52.6 |
| LUCB2936C2DBL | Sitting height, locking | 29 | 737 | 36 | 914 | 21 7/8 | 556 | 126 | 57.2 |
| LUCB2942C2DBL | Sitting height, locking | 29 | 737 | 42 | 1067 | 21 7/8 | 556 | 136 | 61.7 |
| LUCB2948C2DBL | Sitting height, locking | 29 | 737 | 48 | 1219 | 21 7/8 | 556 | 151 | 68.5 |
| LUCB3530C2DBL | Standing height, locking | 35 | 889 | 30 | 762 | 21 7/8 | 556 | 146 | 66.2 |
| LUCB3536C2DBL | Standing height, locking | 35 | 889 | 36 | 914 | 21 7/8 | 556 | 156 | 70.8 |
| LUCB3542C2DBL | Standing height, locking | 35 | 889 | 42 | 1067 | 21 7/8 | 556 | 171 | 77.6 |
| LUCB3548C2DBL | Standing height, locking | 35 | 889 | 48 | 1219 | 21 7/8 | 556 | 181 | 82.1 |

Rev 01/16/20

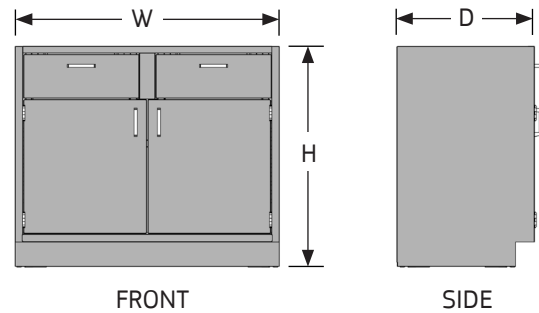
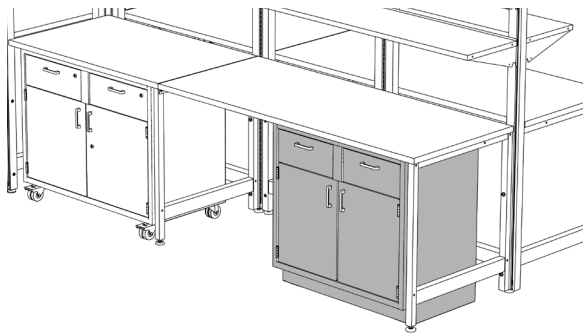

FIXED BASE CABINETS, DOUBLE DRAWER & DOOR

- Built to SEFA standards, Cabinets are constructed of welded 18 and 20 gauge steel with a chemical resistant epoxy powder coat paint finish.
- Drawers have full-extension ball bearing, plated drawer slides.
- Doors have 5-knuckle stainless steel institutional type hinges.
- Sound deadened doors and drawers have "double pan" construction with a bar pull.
- A removable bottom pan and a single full-depth adjustable shelf is included with each cabinet. Additional shelves; consult factory.
- Available with or without locks. Locking cabinets with multiple doors/drawers per unit will have the same key number per unit. Individual units will be keyed randomly and differently from the other. Contact factory for other keying options. Available key numbers are LL226 thru LL327.
- Stationary units are open on top, with a removable back panel and include leveling glides.

NOTES

- » Base cabinets can be used in conjunction with UltraFrame, Lab Legs and support brackets; see pages 2.2, 10.27-10.29.
- » Recessed pulls available; consult factory.

How to Specify

Step 1. Product Number

LUCB Base Cabinet

Step 2. Height

29 29" high 35 35" high

Step 3. Width

30 30" wide 36 36" wide 42 42" wide
48 48" wide

Step 4. Glide, Drawer/Door, Pull Type

G2DB Glide, Double Drawer and Door

Step 5. Locking/Non-Locking

N Non-Locking L Locking

Step 6. Paint Color Code

BK Black
GL Grey Light Smooth
NW Neutral White

| Product Number | Description | Height | | Width | | Depth | | Weight | |
|----------------|------------------------------|--------|------|-------|------|--------|------|--------|------|
| | | in. | [mm] | in. | [mm] | in. | [mm] | lb. | [kg] |
| LUCB2930G2DBN | Sitting height, non-locking | 29 | 737 | 30 | 762 | 21 7/8 | 556 | 110 | 49.9 |
| LUCB2936G2DBN | Sitting height, non-locking | 29 | 737 | 36 | 914 | 21 7/8 | 556 | 120 | 54.4 |
| LUCB2942G2DBN | Sitting height, non-locking | 29 | 737 | 42 | 1067 | 21 7/8 | 556 | 141 | 64.0 |
| LUCB2948G2DBN | Sitting height, non-locking | 29 | 737 | 48 | 1219 | 21 7/8 | 556 | 145 | 65.8 |
| LUCB3530G2DBN | Standing height, non-locking | 35 | 889 | 30 | 762 | 21 7/8 | 556 | 140 | 63.5 |
| LUCB3536G2DBN | Standing height, non-locking | 35 | 889 | 36 | 914 | 21 7/8 | 556 | 150 | 68.0 |
| LUCB3542G2DBN | Standing height, non-locking | 35 | 889 | 42 | 1067 | 21 7/8 | 556 | 165 | 74.8 |
| LUCB3548G2DBN | Standing height, non-locking | 35 | 889 | 48 | 1219 | 21 7/8 | 556 | 175 | 79.4 |
| LUCB2930G2DBL | Sitting height, locking | 29 | 737 | 30 | 762 | 21 7/8 | 556 | 110 | 49.9 |
| LUCB2936G2DBL | Sitting height, locking | 29 | 737 | 36 | 914 | 21 7/8 | 556 | 120 | 54.4 |
| LUCB2942G2DBL | Sitting height, locking | 29 | 737 | 42 | 1067 | 21 7/8 | 556 | 141 | 64.0 |
| LUCB2948G2DBL | Sitting height, locking | 29 | 737 | 48 | 1219 | 21 7/8 | 556 | 145 | 65.8 |
| LUCB3530G2DBL | Standing height, locking | 35 | 889 | 30 | 762 | 21 7/8 | 556 | 140 | 63.5 |
| LUCB3536G2DBL | Standing height, locking | 35 | 889 | 36 | 914 | 21 7/8 | 556 | 150 | 68.0 |
| LUCB3542G2DBL | Standing height, locking | 35 | 889 | 42 | 1067 | 21 7/8 | 556 | 165 | 74.8 |
| LUCB3548G2DBL | Standing height, locking | 35 | 889 | 48 | 1219 | 21 7/8 | 556 | 170 | 77.1 |

Rev 01/16/20

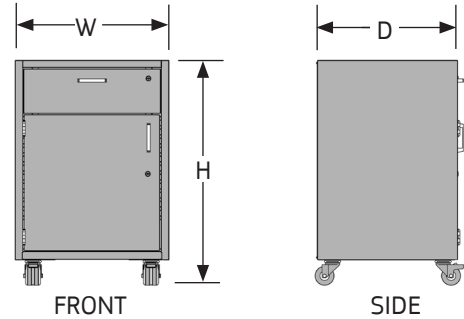
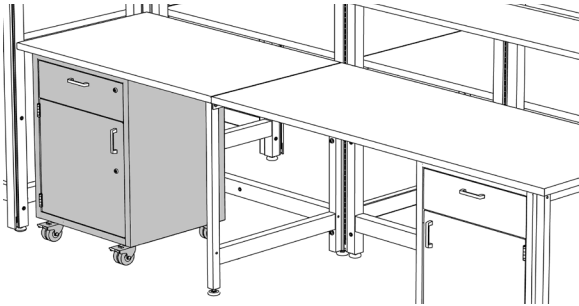

MOBILE BASE CABINETS, SINGLE DRAWER & DOOR

- Built to SEFA standards, Cabinets are constructed of welded 18 and 20 gauge steel with a chemical resistant epoxy powder coat paint finish.
- Drawers have full-extension ball bearing, plated drawer slides.
- Doors have 5-knuckle stainless steel institutional type hinges.
- Sound deadened doors and drawers have "double pan" construction with a bar pull.
- A removable bottom pan and a single full-depth adjustable shelf is included with each cabinet. Additional shelves available, consult factory.
- Available with or without locks. Locking cabinets with multiple doors/drawers per unit will have the same key number per unit. Individual units will be keyed randomly and differently from the other. Contact factory for other keying options. Available key numbers are LL226 thru LL327.
- Mobile units have a solid steel top and back with two front total lock casters and two rear swivel casters.

NOTES

- » Base cabinets can be used in conjunction with UltraFrame, Lab Legs and support brackets; see pages 2.2, 10.27-10.29.
- » Recessed pulls available; consult factory.

How to Specify

Step 1. Product Number

LUCB Base Cabinet

Step 2. Height

29 29" high 35 35" high

Step 3. Width

18 18" wide 24 24" wide

Step 4. Casters, Drawer/Door Combo.

C1 Casters, Single Drawer and Door

Step 5. Hinge Location, Pull Type

LB Left, Bar RB Right, Bar

Step 6. Locking/Non-Locking

N Non-Locking L Locking

Step 7. Paint Color Code

BK Black

GL Grey Light Smooth

NW Neutral White

| Product Number | Description | Height | | Width | | Depth | | Weight | |
|----------------|--|--------|------|-------|------|--------|------|--------|------|
| | | in. | [mm] | in. | [mm] | in. | [mm] | lb. | [kg] |
| LUCB2918C1LBN | Sitting height, left hinged, non-locking | 29 | 737 | 18 | 457 | 21 7/8 | 556 | 86 | 39.0 |
| LUCB2918C1RBN | Sitting height, right hinged, non-locking | 29 | 737 | 18 | 457 | 21 7/8 | 556 | 86 | 39.0 |
| LUCB2924C1LBN | Sitting height, left hinged, non-locking | 29 | 737 | 24 | 610 | 21 7/8 | 556 | 96 | 43.5 |
| LUCB2924C1RBN | Sitting height, right hinged, non-locking | 29 | 737 | 24 | 610 | 21 7/8 | 556 | 96 | 43.5 |
| LUCB3518C1LBN | Standing height, left hinged, non-locking | 35 | 889 | 18 | 457 | 21 7/8 | 556 | 101 | 45.8 |
| LUCB3518C1RBN | Standing height, right hinged, non-locking | 35 | 889 | 18 | 457 | 21 7/8 | 556 | 101 | 45.8 |
| LUCB3524C1LBN | Standing height, left hinged, non-locking | 35 | 889 | 24 | 610 | 21 7/8 | 556 | 111 | 50.3 |
| LUCB3524C1RBN | Standing height, right hinged, non-locking | 35 | 889 | 24 | 610 | 21 7/8 | 556 | 111 | 50.3 |
| LUCB2918C1LBL | Sitting height, left hinged, locking | 29 | 737 | 18 | 457 | 21 7/8 | 556 | 86 | 39.0 |
| LUCB2918C1RBL | Sitting height, right hinged, locking | 29 | 737 | 18 | 457 | 21 7/8 | 556 | 86 | 39.0 |
| LUCB2924C1LBL | Sitting height, left hinged, locking | 29 | 737 | 24 | 610 | 21 7/8 | 556 | 96 | 43.5 |
| LUCB2924C1RBL | Sitting height, right hinged, locking | 29 | 737 | 24 | 610 | 21 7/8 | 556 | 96 | 43.5 |
| LUCB3518C1LBL | Standing height, left hinged, locking | 35 | 889 | 18 | 457 | 21 7/8 | 556 | 101 | 45.8 |
| LUCB3518C1RBL | Standing height, right hinged, locking | 35 | 889 | 18 | 457 | 21 7/8 | 556 | 101 | 45.8 |
| LUCB3524C1LBL | Standing height, left hinged, locking | 35 | 889 | 24 | 610 | 21 7/8 | 556 | 111 | 50.3 |
| LUCB3524C1RBL | Standing height, right hinged, locking | 35 | 889 | 24 | 610 | 21 7/8 | 556 | 111 | 50.3 |

Rev 01/16/20

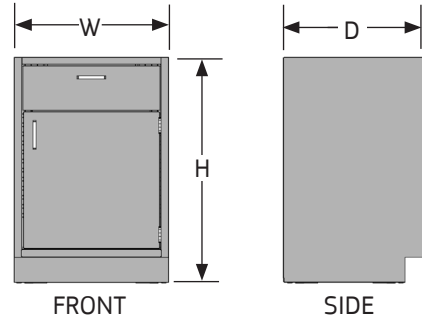
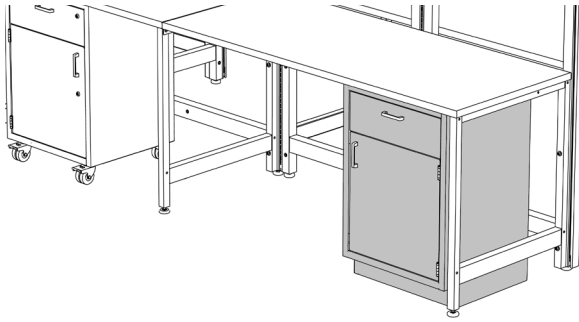

FIXED BASE CABINETS, SINGLE DRAWER & DOOR

- Built to SEFA standards, Cabinets are constructed of welded 18 and 20 gauge steel with a chemical resistant epoxy powder coat paint finish.
- Drawers have full-extension ball bearing, plated drawer slides.
- Doors have 5-knuckle stainless steel institutional type hinges.
- Sound deadened doors and drawers have "double pan" construction with a bar pull.
- A removable bottom pan and a single full-depth adjustable shelf is included with each cabinet. Additional shelves available, consult factory.
- Available with or without locks. Locking cabinets with multiple doors/drawers per unit will have the same key number per unit. Individual units will be keyed randomly and differently from the other. Contact factory for other keying options. Available key numbers are LL226 thru LL327.
- Stationary units are open on top, with a removable back panel and include leveling glides.

NOTES

- » Base cabinets can be used in conjunction with UltraFrame, Lab Legs and support brackets; see pages 2.2, 10.27-10.29.
- » Recessed pulls available; consult factory.

How to Specify

Step 1. Product Number

LUCB Base Cabinet

Step 2. Height

29 29" high 35 35" high

Step 3. Width

18 18" wide 24 24" wide

Step 4. Glide, Drawer/Door Combo.

G1 Glide Base, Single Drawer and Door

Step 5. Hinge Location, Pull Type

LB Left, Bar RB Right, Bar

Step 6. Locking/Non-Locking

N Non-Locking L Locking

Step 7. Paint Color Code

BK Black
 GL Grey Light Smooth
 NW Neutral White

| Product Number | Description | Height | | Width | | Depth | | Weight | |
|----------------|--|--------|------|-------|------|--------|------|--------|------|
| | | in. | [mm] | in. | [mm] | in. | [mm] | lb. | [kg] |
| LUCB2918G1LBN | Sitting height, left hinged, non-locking | 29 | 737 | 18 | 457 | 21 7/8 | 556 | 80 | 36.3 |
| LUCB2918G1RBN | Sitting height, right hinged, non-locking | 29 | 737 | 18 | 457 | 21 7/8 | 556 | 80 | 36.3 |
| LUCB2924G1LBN | Sitting height, left hinged, non-locking | 29 | 737 | 24 | 610 | 21 7/8 | 556 | 90 | 40.8 |
| LUCB2924G1RBN | Sitting height, right hinged, non-locking | 29 | 737 | 24 | 610 | 21 7/8 | 556 | 90 | 40.8 |
| LUCB3518G1LBN | Standing height, left hinged, non-locking | 35 | 889 | 18 | 457 | 21 7/8 | 556 | 95 | 43.1 |
| LUCB3518G1RBN | Standing height, right hinged, non-locking | 35 | 889 | 18 | 457 | 21 7/8 | 556 | 95 | 43.1 |
| LUCB3524G1LBN | Standing height, left hinged, non-locking | 35 | 889 | 24 | 610 | 21 7/8 | 556 | 105 | 47.6 |
| LUCB3524G1RBN | Standing height, right hinged, non-locking | 35 | 889 | 24 | 610 | 21 7/8 | 556 | 105 | 47.6 |
| LUCB2918G1LBL | Sitting height, left hinged, locking | 29 | 737 | 18 | 457 | 21 7/8 | 556 | 80 | 36.3 |
| LUCB2918G1RBL | Sitting height, right hinged, locking | 29 | 737 | 18 | 457 | 21 7/8 | 556 | 80 | 36.3 |
| LUCB2924G1LBL | Sitting height, left hinged, locking | 29 | 737 | 24 | 610 | 21 7/8 | 556 | 90 | 40.8 |
| LUCB2924G1RBL | Sitting height, right hinged, locking | 29 | 737 | 24 | 610 | 21 7/8 | 556 | 90 | 40.8 |
| LUCB3518G1LBL | Standing height, left hinged, locking | 35 | 889 | 18 | 457 | 21 7/8 | 556 | 95 | 43.1 |
| LUCB3518G1RBL | Standing height, right hinged, locking | 35 | 889 | 18 | 457 | 21 7/8 | 556 | 95 | 43.1 |
| LUCB3524G1LBL | Standing height, left hinged, locking | 35 | 889 | 24 | 610 | 21 7/8 | 556 | 105 | 47.6 |
| LUCB3524G1RBL | Standing height, right hinged, locking | 35 | 889 | 24 | 610 | 21 7/8 | 556 | 105 | 47.6 |

Rev 01/16/20

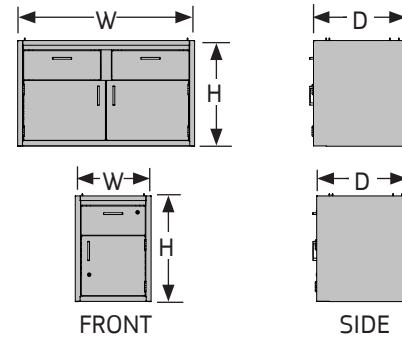
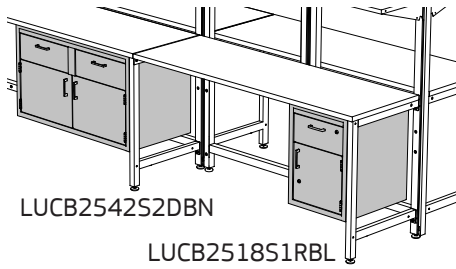

SUSPENDED BASE CABINETS, DRAWER/DOOR

- Suspended Base Cabinets can be hung from the underside of surfaces and 4-Legged Table Cabinet Mounting Brackets.
- Built to SEFA standards, Cabinets are constructed of welded 18 and 20 gauge steel with a chemical resistant epoxy powder coat paint finish.
- Drawers have full-extension ball bearing, plated drawer slides.
- Doors have 5-knuckle stainless steel institutional type hinges.
- Sound deadened doors and drawers have "double pan" construction with a bar pull.
- A removable bottom pan and a single full-depth adjustable shelf is included with each cabinet. Additional shelves available; consult factory.
- Available with or without locks. Locking cabinets with multiple doors/drawers per unit will have the same key number per unit. Individual units will be keyed randomly and differently from the other. Contact factory for other keying options. Available key numbers are LL226 thru LL327.
- Units are open on top and have a solid steel back panel.

NOTES

- » Load capacity (includes cabinet and content) cannot exceed 500 lbs. Load capacity of the suspended cabinet does not supercede support component load rating.
- » The suspended component(s) reduces the surface load capacity by an amount equal to the suspended component and its contents.
- » Recessed pulls available; consult factory.
- » 4-Legged Table Cabinet Mounting Brackets sold separately; see page 10.16.

How to Specify

Step 1. Product Number

LUCB Base Cabinet

Step 2. Height

25 25" high

Step 3. Width

18 18" wide 24 24" wide 30 30" wide
36 36" wide 42 42" wide 48 48" wide

Step 4. Suspended, Drawer/Door Combo.

S1 Single S2 Double

Step 5. Hinge Location, Pull Type

LB Left, Bar RB Right, Bar D Double Door

Step 6. Locking/Non-Locking

N Non-Locking L Locking

Step 7. Paint Color Code

BK Black
GL Grey Light Smooth
NW Neutral White

| Product Number | Description | Height | | Width | | Depth | | Weight | |
|----------------|--------------------------------------|--------|------|-------|------|--------|------|--------|------|
| | | in. | [mm] | in. | [mm] | in. | [mm] | lb. | [kg] |
| LUCB2518S1LBN | Suspended, left hinged, non-locking | 25 | 635 | 18 | 457 | 21 7/8 | 556 | 86 | 39.0 |
| LUCB2518S1RBN | Suspended, right hinged, non-locking | 25 | 635 | 18 | 457 | 21 7/8 | 556 | 86 | 39.0 |
| LUCB2524S1LBN | Suspended, left hinged, non-locking | 25 | 635 | 24 | 610 | 21 7/8 | 556 | 111 | 50.3 |
| LUCB2524S1RBN | Suspended, right hinged, non-locking | 25 | 635 | 24 | 610 | 21 7/8 | 556 | 111 | 50.3 |
| LUCB2518S1LBL | Suspended, left hinged, locking | 25 | 635 | 18 | 457 | 21 7/8 | 556 | 96 | 43.5 |
| LUCB2518S1RBL | Suspended, right hinged, locking | 25 | 635 | 18 | 457 | 21 7/8 | 556 | 96 | 43.5 |
| LUCB2524S1LBL | Suspended, left hinged, locking | 25 | 635 | 24 | 610 | 21 7/8 | 556 | 101 | 45.8 |
| LUCB2524S1RBL | Suspended, right hinged, locking | 25 | 635 | 24 | 610 | 21 7/8 | 556 | 101 | 45.8 |
| LUCB2530S2DBN | Suspended, double door, non-locking | 25 | 635 | 30 | 762 | 21 7/8 | 556 | 110 | 49.9 |
| LUCB2536S2DBN | Suspended, double door, non-locking | 25 | 635 | 36 | 914 | 21 7/8 | 556 | 120 | 54.4 |
| LUCB2542S2DBN | Suspended, double door, non-locking | 25 | 635 | 42 | 1067 | 21 7/8 | 556 | 141 | 64.0 |
| LUCB2548S2DBN | Suspended, double door, non-locking | 25 | 635 | 48 | 1219 | 21 7/8 | 556 | 151 | 68.5 |
| LUCB2530S2DBL | Suspended, double door, locking | 25 | 635 | 30 | 762 | 21 7/8 | 556 | 110 | 49.9 |
| LUCB2536S2DBL | Suspended, double door, locking | 25 | 635 | 36 | 914 | 21 7/8 | 556 | 120 | 54.4 |
| LUCB2542S2DBL | Suspended, double door, locking | 25 | 635 | 42 | 1067 | 21 7/8 | 556 | 141 | 64.0 |
| LUCB2548S2DBL | Suspended, double door, locking | 25 | 635 | 48 | 1219 | 21 7/8 | 556 | 151 | 68.5 |

Rev 01/16/20

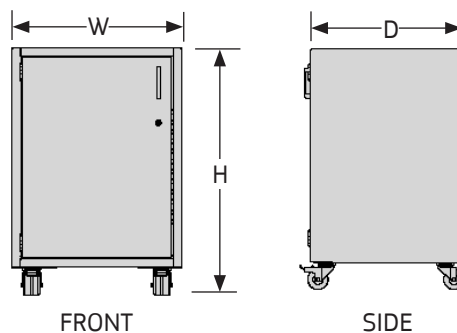
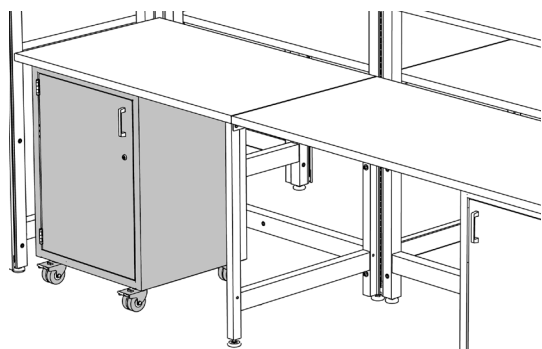

MOBILE BASE CABINETS, SINGLE DOOR

- Built to SEFA standards, Cabinets are constructed of welded 18 and 20 gauge steel with a chemical resistant epoxy powder coat paint finish.
- Doors have 5-knuckle stainless steel institutional type hinges.
- Sound deadened doors have "double pan" construction with a bar pull.
- A removable bottom pan and a single full-depth adjustable shelf is included with each cabinet. Additional shelves available; consult factory.
- Available with or without locks. Locking cabinets with multiple doors/drawers per unit will have the same key number per unit. Individual units will be keyed randomly and differently from the other. Contact factory for other keying options. Available key numbers are LL226 thru LL327.
- Mobile units have a solid steel top and back with two front total lock casters and two rear swivel casters.

NOTES

- » Base cabinets can be used in conjunction with UltraFrame, Lab Legs and support brackets; see pages 2.2 - 2.3 and 10.25 - 10.27.
- » Recessed pulls available; consult factory.

How to Specify

Step 1. Product Number

LUCB Base Cabinet

Step 2. Height

29 29" high 35 35" high

Step 3. Width

18 18" wide 24 24" wide

Step 4. Casters, Door

C0 Casters, Single Door

Step 5. Hinge Location, Pull Type

LB Left, Bar RB Right, Bar

Step 6. Locking/Non-Locking

N Non-Locking L Locking

Step 7. Paint Color Code

BK Black
GL Grey Light Smooth
NW Neutral White

| Product Number | Description | Height | | Width | | Depth | | Weight | |
|----------------|--|--------|------|-------|------|--------|------|--------|------|
| | | in. | [mm] | in. | [mm] | in. | [mm] | lb. | [kg] |
| LUCB2918COLBN | Sitting height, left hinged, non-locking | 29 | 737 | 18 | 457 | 21 7/8 | 556 | 81 | 36.7 |
| LUCB2918CORBN | Sitting height, right hinged, non-locking | 29 | 737 | 18 | 457 | 21 7/8 | 556 | 81 | 36.7 |
| LUCB2924COLBN | Sitting height, left hinged, non-locking | 29 | 737 | 24 | 610 | 21 7/8 | 556 | 91 | 41.3 |
| LUCB2924CORBN | Sitting height, right hinged, non-locking | 29 | 737 | 24 | 610 | 21 7/8 | 556 | 91 | 41.3 |
| LUCB3518COLBN | Standing height, left hinged, non-locking | 35 | 889 | 18 | 457 | 21 7/8 | 556 | 91 | 41.3 |
| LUCB3518CORBN | Standing height, right hinged, non-locking | 35 | 889 | 18 | 457 | 21 7/8 | 556 | 91 | 41.3 |
| LUCB3524COLBN | Standing height, left hinged, non-locking | 35 | 889 | 24 | 610 | 21 7/8 | 556 | 101 | 45.8 |
| LUCB3524CORBN | Standing height, right hinged, non-locking | 35 | 889 | 24 | 610 | 21 7/8 | 556 | 101 | 45.8 |
| LUCB2918COLBL | Sitting height, left hinged, locking | 29 | 737 | 18 | 457 | 21 7/8 | 556 | 81 | 36.7 |
| LUCB2918CORBL | Sitting height, right hinged, locking | 29 | 737 | 18 | 457 | 21 7/8 | 556 | 81 | 36.7 |
| LUCB2924COLBL | Sitting height, left hinged, locking | 29 | 737 | 24 | 610 | 21 7/8 | 556 | 91 | 41.3 |
| LUCB2924CORBL | Sitting height, right hinged, locking | 29 | 737 | 24 | 610 | 21 7/8 | 556 | 91 | 41.3 |
| LUCB3518COLBL | Standing height, left hinged, locking | 35 | 889 | 18 | 457 | 21 7/8 | 556 | 91 | 41.3 |
| LUCB3518CORBL | Standing height, right hinged, locking | 35 | 889 | 18 | 457 | 21 7/8 | 556 | 91 | 41.3 |
| LUCB3524COLBL | Standing height, left hinged, locking | 35 | 889 | 24 | 610 | 21 7/8 | 556 | 101 | 45.8 |
| LUCB3524CORBL | Standing height, right hinged, locking | 35 | 889 | 24 | 610 | 21 7/8 | 556 | 101 | 45.8 |

Rev 01/16/20

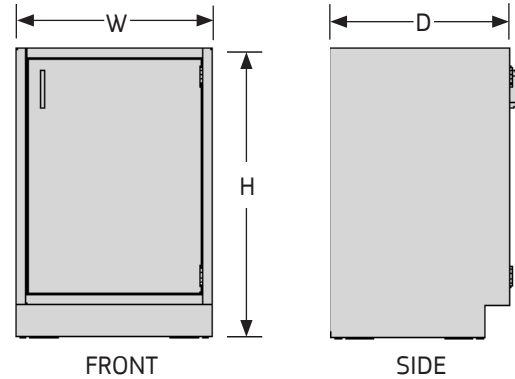
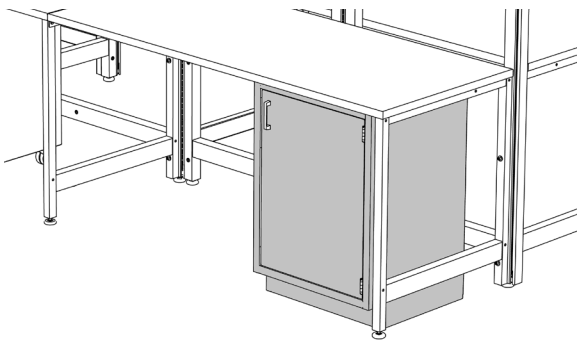

FIXED BASE CABINETS, SINGLE DOOR

- Built to SEFA standards, Cabinets are constructed of welded 18 and 20 gauge steel with a chemical resistant epoxy powder coat paint finish.
- Doors have 5-knuckle stainless steel institutional type hinges.
- Sound deadened doors have "double pan" construction with a bar pull.
- A removable bottom pan and a single full-depth adjustable shelf is included with each cabinet. Additional shelves available; consult factory.
- Available with or without locks. Locking cabinets with multiple doors/drawers per unit will have the same key number per unit. Individual units will be keyed randomly and differently from the other. Contact factory for other keying options. Available key numbers are LL226 thru LL327.
- Stationary units are open on top, with a removable back panel and include leveling glides.

NOTES

- » Base cabinets can be used in conjunction with UltraFrame, Lab Legs and support brackets; see pages 2.2 - 2.3 and 10.25 - 10.27.
- » Recessed pulls available; consult factory.

How to Specify

Step 1. Product Number

LUCB Base Cabinet

Step 2. Height

29 29" high 35 35" high

Step 3. Width

18 18" wide 24 24" wide

Step 4. Glide, Door

GO Glide, Single Door

Step 5. Hinge Location, Pull Type

LB Left, Bar RB Right, Bar

Step 6. Locking/Non-Locking

N Non-Locking L Locking

Step 7. Paint Color Code

BK Black
GL Grey Light Smooth
NW Neutral White

| Product Number | Description | Height | | Width | | Depth | | Weight | |
|----------------|--|--------|------|-------|------|--------|------|--------|------|
| | | in. | [mm] | in. | [mm] | in. | [mm] | lb. | [kg] |
| LUCB2918GOLBN | Sitting height, left hinged, non-locking | 29 | 737 | 18 | 457 | 21 7/8 | 556 | 75 | 34.0 |
| LUCB2918GORBN | Sitting height, right hinged, non-locking | 29 | 737 | 18 | 457 | 21 7/8 | 556 | 75 | 34.0 |
| LUCB2924GOLBN | Sitting height, left hinged, non-locking | 29 | 737 | 24 | 610 | 21 7/8 | 556 | 85 | 38.6 |
| LUCB2924GORBN | Sitting height, right hinged, non-locking | 29 | 737 | 24 | 610 | 21 7/8 | 556 | 85 | 38.6 |
| LUCB3518GOLBN | Standing height, left hinged, non-locking | 35 | 889 | 18 | 457 | 21 7/8 | 556 | 85 | 38.6 |
| LUCB3518GORBN | Standing height, right hinged, non-locking | 35 | 889 | 18 | 457 | 21 7/8 | 556 | 85 | 38.6 |
| LUCB3524GOLBN | Standing height, left hinged, non-locking | 35 | 889 | 24 | 610 | 21 7/8 | 556 | 95 | 43.1 |
| LUCB3524GORBN | Standing height, right hinged, non-locking | 35 | 889 | 24 | 610 | 21 7/8 | 556 | 95 | 43.1 |
| LUCB2918GOLBL | Sitting height, left hinged, locking | 29 | 737 | 18 | 457 | 21 7/8 | 556 | 75 | 34.0 |
| LUCB2918GORBL | Sitting height, right hinged, locking | 29 | 737 | 18 | 457 | 21 7/8 | 556 | 75 | 34.0 |
| LUCB2924GOLBL | Sitting height, left hinged, locking | 29 | 737 | 24 | 610 | 21 7/8 | 556 | 85 | 38.6 |
| LUCB2924GORBL | Sitting height, right hinged, locking | 29 | 737 | 24 | 610 | 21 7/8 | 556 | 85 | 38.6 |
| LUCB3518GOLBL | Standing height, left hinged, locking | 35 | 889 | 18 | 457 | 21 7/8 | 556 | 85 | 38.6 |
| LUCB3518GORBL | Standing height, right hinged, locking | 35 | 889 | 18 | 457 | 21 7/8 | 556 | 85 | 38.6 |
| LUCB3524GOLBL | Standing height, left hinged, locking | 35 | 889 | 24 | 610 | 21 7/8 | 556 | 95 | 43.1 |
| LUCB3524GORBL | Standing height, right hinged, locking | 35 | 889 | 24 | 610 | 21 7/8 | 556 | 95 | 43.1 |

Rev 01/16/20

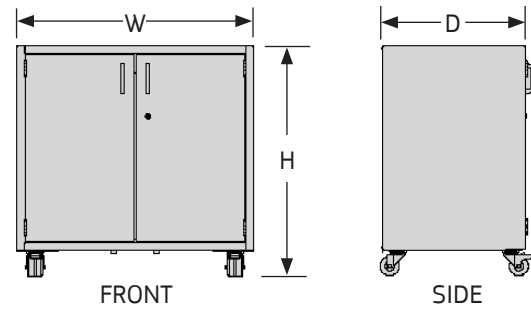
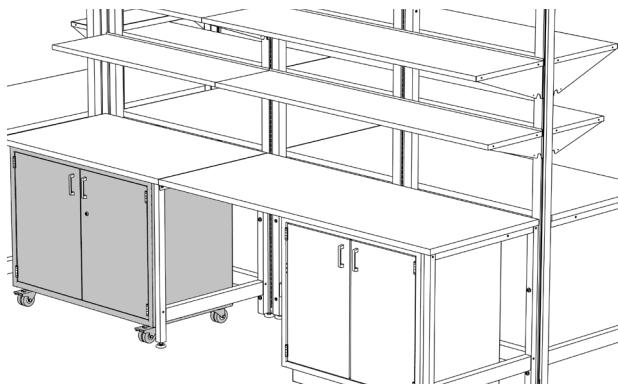

MOBILE BASE CABINETS, DOUBLE DOOR

- Built to SEFA standards, Cabinets are constructed of welded 18 and 20 gauge steel with a chemical resistant epoxy powder coat paint finish.
- Doors have 5-knuckle stainless steel institutional type hinges.
- Sound deadened doors have "double pan" construction with a bar pull.
- A removable bottom pan and a single full-depth adjustable shelf is included with each cabinet. Additional shelves available, consult factory.
- Available with or without locks. Locking cabinets with multiple doors/drawers per unit will have the same key number per unit. Individual units will be keyed randomly and differently from the other. Contact factory for other keying options. Available key numbers are LL226 thru LL327.
- Mobile units have a solid steel top and back with two front total lock casters and two rear swivel casters.

NOTES

- » Base cabinets can be used in conjunction with UltraFrame, Lab Legs and support brackets; see pages 2.2 - 2.3 and 10.25 - 10.27.
- » Recessed pulls available; consult factory.

How to Specify

Step 1. Product Number

LUCB Base Cabinet

Step 2. Height

29 29" high 35 35" high

Step 3. Width

30 30" wide 36 36" wide 42 42" wide
48 48" wide

Step 4. Casters, Door, Pull Type

CODB Casters, Double Door, Bar Pull

Step 5. Locking/Non-Locking

N Non-Locking L Locking

Step 6. Paint Color Code

BK Black
GL Grey Light Smooth
NW Neutral White

| Product Number | Description | Height | | Width | | Depth | | Weight | |
|----------------|------------------------------|--------|------|-------|------|--------|------|--------|------|
| | | in. | [mm] | in. | [mm] | in. | [mm] | lb. | [kg] |
| LUCB2930CODBN | Sitting height, non-locking | 29 | 737 | 30 | 762 | 21 7/8 | 556 | 111 | 50.3 |
| LUCB2936CODBN | Sitting height, non-locking | 29 | 737 | 36 | 914 | 21 7/8 | 556 | 121 | 54.9 |
| LUCB2942CODBN | Sitting height, non-locking | 29 | 737 | 42 | 1067 | 21 7/8 | 556 | 131 | 59.4 |
| LUCB2948CODBN | Sitting height, non-locking | 29 | 737 | 48 | 1219 | 21 7/8 | 556 | 141 | 64.0 |
| LUCB3530CODBN | Standing height, non-locking | 35 | 889 | 30 | 762 | 21 7/8 | 556 | 131 | 59.4 |
| LUCB3536CODBN | Standing height, non-locking | 35 | 889 | 36 | 914 | 21 7/8 | 556 | 136 | 61.7 |
| LUCB3542CODBN | Standing height, non-locking | 35 | 889 | 42 | 1067 | 21 7/8 | 556 | 156 | 70.8 |
| LUCB3548CODBN | Standing height, non-locking | 35 | 889 | 48 | 1219 | 21 7/8 | 556 | 161 | 73.0 |
| LUCB2930CODBL | Sitting height, locking | 29 | 737 | 30 | 762 | 21 7/8 | 556 | 111 | 50.3 |
| LUCB2936CODBL | Sitting height, locking | 29 | 737 | 36 | 914 | 21 7/8 | 556 | 121 | 54.9 |
| LUCB2942CODBL | Sitting height, locking | 29 | 737 | 42 | 1067 | 21 7/8 | 556 | 131 | 59.4 |
| LUCB2948CODBL | Sitting height, locking | 29 | 737 | 48 | 1219 | 21 7/8 | 556 | 141 | 64.0 |
| LUCB3530CODBL | Standing height, locking | 35 | 889 | 30 | 762 | 21 7/8 | 556 | 131 | 59.4 |
| LUCB3536CODBL | Standing height, locking | 35 | 889 | 36 | 914 | 21 7/8 | 556 | 136 | 61.7 |
| LUCB3542CODBL | Standing height, locking | 35 | 889 | 42 | 1067 | 21 7/8 | 556 | 156 | 70.8 |
| LUCB3548CODBL | Standing height, locking | 35 | 889 | 48 | 1219 | 21 7/8 | 556 | 161 | 73.0 |

Rev 01/16/20

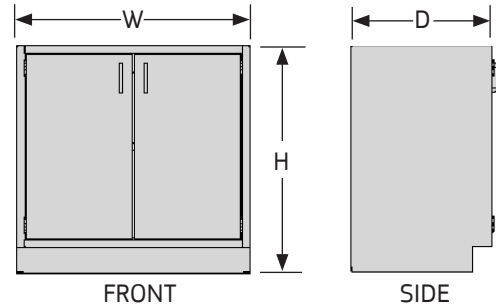
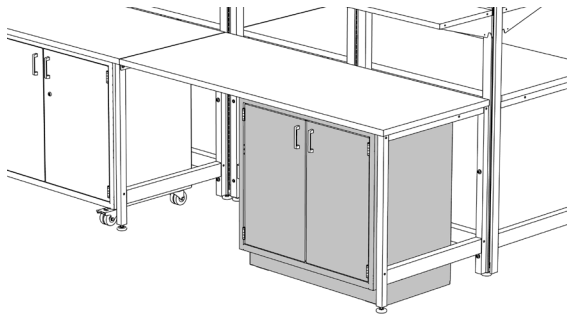

FIXED BASE CABINETS, DOUBLE DOOR

- Built to SEFA standards, Cabinets are constructed of welded 18 and 20 gauge steel with a chemical resistant epoxy powder coat paint finish.
- Doors have 5-knuckle stainless steel institutional type hinges.
- Sound deadened doors have "double pan" construction with a bar pull.
- A removable bottom pan and a single full-depth adjustable shelf is included with each cabinet. Additional shelves available, consult factory.
- Available with or without locks. Locking cabinets with multiple doors/drawers per unit will have the same key number per unit. Individual units will be keyed randomly and differently from the other. Contact factory for other keying options. Available key numbers are LL226 thru LL327.
- Stationary units are open on top, with a removable back panel and include leveling glides.

NOTES

- » Base cabinets can be used in conjunction with UltraFrame, Lab Legs and support brackets; see pages 2.2 - 2.3 and 10.25 - 10.27.
- » Recessed pulls available; consult factory.

How to Specify

Step 1. Product Number

LUCB Base Cabinet

Step 2. Height

29 29" high 35 35" high

Step 3. Width

30 30" wide 36 36" wide 42 42" wide
48 48" wide

Step 4. Glide

G0 Glide

Step 5. Door, Pull Type

DB Double Door, Bar

Step 6. Locking/Non-Locking

N Non-Locking L Locking

Step 7. Paint Color Code

BK Black
GL Grey Light Smooth
NW Neutral White

| Product Number | Description | Height | | Width | | Depth | | Weight | |
|----------------|------------------------------|--------|------|-------|------|--------|------|--------|------|
| | | in. | [mm] | in. | [mm] | in. | [mm] | lb. | [kg] |
| LUCB2930G0DBN | Sitting height, non-locking | 29 | 737 | 30 | 762 | 21 7/8 | 556 | 105 | 47.6 |
| LUCB2936G0DBN | Sitting height, non-locking | 29 | 737 | 36 | 914 | 21 7/8 | 556 | 115 | 52.2 |
| LUCB2942G0DBN | Sitting height, non-locking | 29 | 737 | 42 | 1067 | 21 7/8 | 556 | 125 | 56.7 |
| LUCB2948G0DBN | Sitting height, non-locking | 29 | 737 | 48 | 1219 | 21 7/8 | 556 | 135 | 61.2 |
| LUCB3530G0DBN | Standing height, non-locking | 35 | 889 | 30 | 762 | 21 7/8 | 556 | 125 | 56.7 |
| LUCB3536G0DBN | Standing height, non-locking | 35 | 889 | 36 | 914 | 21 7/8 | 556 | 130 | 59.0 |
| LUCB3542G0DBN | Standing height, non-locking | 35 | 889 | 42 | 1067 | 21 7/8 | 556 | 150 | 68.0 |
| LUCB3548G0DBN | Standing height, non-locking | 35 | 889 | 48 | 1219 | 21 7/8 | 556 | 155 | 70.3 |
| LUCB2930G0DBL | Sitting height, locking | 29 | 737 | 30 | 762 | 21 7/8 | 556 | 105 | 47.6 |
| LUCB2936G0DBL | Sitting height, locking | 29 | 737 | 36 | 914 | 21 7/8 | 556 | 115 | 52.2 |
| LUCB2942G0DBL | Sitting height, locking | 29 | 737 | 42 | 1067 | 21 7/8 | 556 | 125 | 56.7 |
| LUCB2948G0DBL | Sitting height, locking | 29 | 737 | 48 | 1219 | 21 7/8 | 556 | 135 | 61.2 |
| LUCB3530G0DBL | Standing height, locking | 35 | 889 | 30 | 762 | 21 7/8 | 556 | 125 | 56.7 |
| LUCB3536G0DBL | Standing height, locking | 35 | 889 | 36 | 914 | 21 7/8 | 556 | 130 | 59.0 |
| LUCB3542G0DBL | Standing height, locking | 35 | 889 | 42 | 1067 | 21 7/8 | 556 | 150 | 68.0 |
| LUCB3548G0DBL | Standing height, locking | 35 | 889 | 48 | 1219 | 21 7/8 | 556 | 155 | 70.3 |

Rev 01/16/20

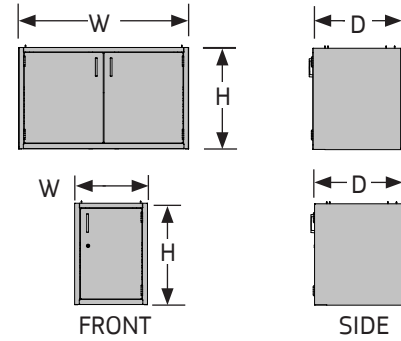
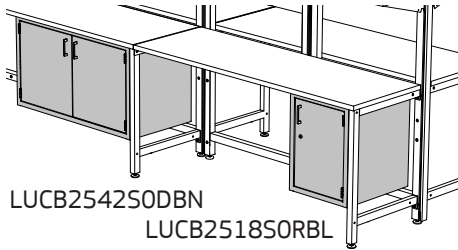

SUSPENDED BASE CABINETS, SINGLE & DBL. DOOR

- Suspended Base Cabinets can be hung from the underside of surfaces and 4-Legged Table Cabinet Mounting Brackets.
- Built to SEFA standards, cabinets are constructed of welded 18 and 20 gauge steel with a chemical resistant epoxy powder coat paint finish.
- Sound deadened doors and drawers have "double pan" construction with a bar pull.
- Drawers have full-extension ball bearing, plated drawer slides.
- Doors have 5-knuckle stainless steel institutional type hinges.
- A removable bottom pan and a single full-depth adjustable shelf is included with each cabinet. Additional shelves available, consult factory.
- Available with or without locks. Locking cabinets with multiple doors/drawers per unit will have the same key number per unit. Individual units will be keyed randomly and differently from the other. Contact factory for other keying options. Available key numbers are LL226 thru LL327.
- Units are open on top and have a solid back panel.

NOTES

- » Load capacity (includes cabinet and content) cannot exceed 500 lbs. Load capacity of the suspended cabinet does not supercede support component load rating.
- » Suspended component(s) reduce the surface load capacity by an amount equal to the suspended component and its contents.
- » Recessed pulls available; consult factory.
- » 4-Legged Table Cabinet Mounting Brackets sold separately; see page 10.16.

How to Specify

Step 1. Product Number

LUCB Base Cabinet

Step 2. Height

25 25" high

Step 3. Width

18 18" wide 24 24" wide 30 30" wide
36 36" wide 42 42" wide 48 48" wide

Step 4. Suspended, Door

50 Single Door 50D Double Door

Step 5. Hinge Location, Pull Type

LB Left, Bar RB Right, Bar D Double Door

Step 6. Locking/Non-Locking

N Non-Locking L Locking

Step 7. Paint Color Code

BK Black
GL Grey Light Smooth
NW Neutral White

| Product Number | Description | Height | | Width | | Depth | | Weight | |
|----------------|--------------------------------------|--------|------|-------|------|--------|------|--------|------|
| | | in. | [mm] | in. | [mm] | in. | [mm] | lb. | [kg] |
| LUCB2518S0LBN | Suspended, left hinged, non-locking | 25 | 635 | 18 | 457 | 21 7/8 | 556 | 86 | 39.0 |
| LUCB2518S0RBN | Suspended, right hinged, non-locking | 25 | 635 | 18 | 457 | 21 7/8 | 556 | 86 | 39.0 |
| LUCB2524S0LBN | Suspended, left hinged, non-locking | 25 | 635 | 24 | 610 | 21 7/8 | 556 | 101 | 45.8 |
| LUCB2524S0RBN | Suspended, right hinged, non-locking | 25 | 635 | 24 | 610 | 21 7/8 | 556 | 101 | 45.8 |
| LUCB2518S0LBL | Suspended, left hinged, locking | 25 | 635 | 18 | 457 | 21 7/8 | 556 | 86 | 39.0 |
| LUCB2518S0RBL | Suspended, right hinged, locking | 25 | 635 | 18 | 457 | 21 7/8 | 556 | 86 | 39.0 |
| LUCB2524S0LBL | Suspended, left hinged, locking | 25 | 635 | 24 | 610 | 21 7/8 | 556 | 101 | 45.8 |
| LUCB2524S0RBL | Suspended, right hinged, locking | 25 | 635 | 24 | 610 | 21 7/8 | 556 | 101 | 45.8 |
| LUCB2530S0DBN | Suspended, double door, non-locking | 25 | 635 | 30 | 762 | 21 7/8 | 556 | 111 | 50.3 |
| LUCB2536S0DBN | Suspended, double door, non-locking | 25 | 635 | 36 | 914 | 21 7/8 | 556 | 121 | 54.9 |
| LUCB2542S0DBN | Suspended, double door, non-locking | 25 | 635 | 42 | 1067 | 21 7/8 | 556 | 131 | 59.4 |
| LUCB2548S0DBN | Suspended, double door, non-locking | 25 | 635 | 48 | 1219 | 21 7/8 | 556 | 141 | 64.0 |
| LUCB2530S0DBL | Suspended, double door, locking | 25 | 635 | 30 | 762 | 21 7/8 | 556 | 131 | 59.4 |
| LUCB2536S0DBL | Suspended, double door, locking | 25 | 635 | 36 | 914 | 21 7/8 | 556 | 136 | 61.7 |
| LUCB2542S0DBL | Suspended, double door, locking | 25 | 635 | 42 | 1067 | 21 7/8 | 556 | 156 | 70.8 |
| LUCB2548S0DBL | Suspended, double door, locking | 25 | 635 | 48 | 1219 | 21 7/8 | 556 | 161 | 73.0 |

Rev 01/16/20

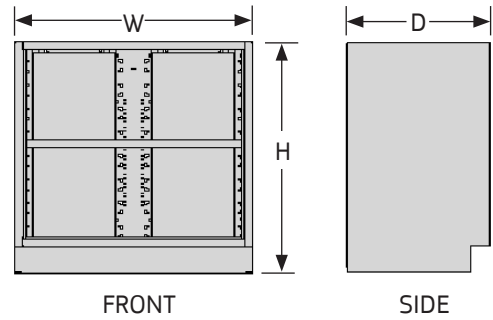
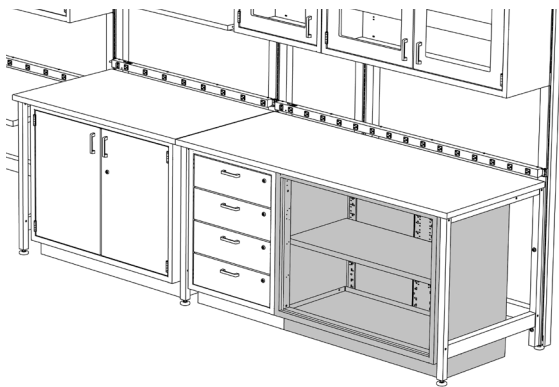

FIXED BASE CABINETS, OPEN UNIT

- Cabinets are constructed of welded 18 and 20 gauge steel with a chemical resistant epoxy powder coat paint finish.
- Built to SEFA standards.
- A removable bottom pan and a single full-depth adjustable shelf is included with each cabinet. Additional shelves available; consult factory.

NOTES

- » Base cabinets can be used in conjunction with UltraFrame, Lab Legs and support brackets; see pages 2.2 - 2.3 and 10.25 - 10.27.
- » Open unit is only available with glides.

How to Specify

Step 1. Product Number

LUCB Base Cabinet

Step 2. Height

29 29" high 35 35" high

Step 3. Width

18 18" wide 24 24" wide 30 30" wide
36 36" wide 42 42" wide 48 48" wide

Step 4. Glide, Open Unit

G0 Glide

Step 5. Shelf

0000 Bottom Pan, Single Adjustable Shelf

Step 6. Paint Color Code

BK Black
GL Grey Light Smooth
NW Neutral White

| Product Number | Description | Height | | Width | | Depth | | Weight | |
|----------------|-------------------------------------|--------|------|-------|------|--------|------|--------|------|
| | | in. | [mm] | in. | [mm] | in. | [mm] | lb. | [kg] |
| LUCB2918G0000 | Sitting height, open, single shelf | 29 | 737 | 18 | 457 | 21 7/8 | 556 | 65 | 29.5 |
| LUCB2924G0000 | Sitting height, open, single shelf | 29 | 737 | 24 | 610 | 21 7/8 | 556 | 75 | 34.0 |
| LUCB2930G0000 | Sitting height, open, single shelf | 29 | 737 | 30 | 762 | 21 7/8 | 556 | 90 | 40.8 |
| LUCB2936G0000 | Sitting height, open, single shelf | 29 | 737 | 36 | 914 | 21 7/8 | 556 | 100 | 45.4 |
| LUCB2942G0000 | Sitting height, open, single shelf | 29 | 737 | 42 | 1067 | 21 7/8 | 556 | 105 | 47.6 |
| LUCB2948G0000 | Sitting height, open, single shelf | 29 | 737 | 48 | 1219 | 21 7/8 | 556 | 115 | 52.2 |
| LUCB3518G0000 | Standing height, open, single shelf | 35 | 889 | 18 | 457 | 21 7/8 | 556 | 75 | 34.0 |
| LUCB3524G0000 | Standing height, open, single shelf | 35 | 889 | 24 | 610 | 21 7/8 | 556 | 80 | 36.3 |
| LUCB3530G0000 | Standing height, open, single shelf | 35 | 889 | 30 | 762 | 21 7/8 | 556 | 110 | 49.9 |
| LUCB3536G0000 | Standing height, open, single shelf | 35 | 889 | 36 | 914 | 21 7/8 | 556 | 110 | 49.9 |
| LUCB3542G0000 | Standing height, open, single shelf | 35 | 889 | 42 | 1067 | 21 7/8 | 556 | 115 | 52.2 |
| LUCB3548G0000 | Standing height, open, single shelf | 35 | 889 | 48 | 1219 | 21 7/8 | 556 | 125 | 56.7 |

Rev 03/29/10

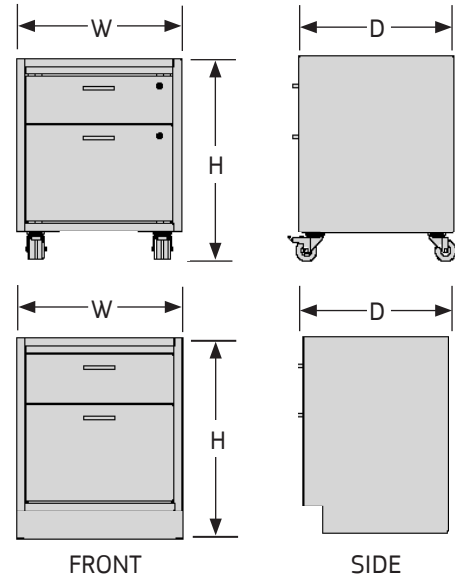
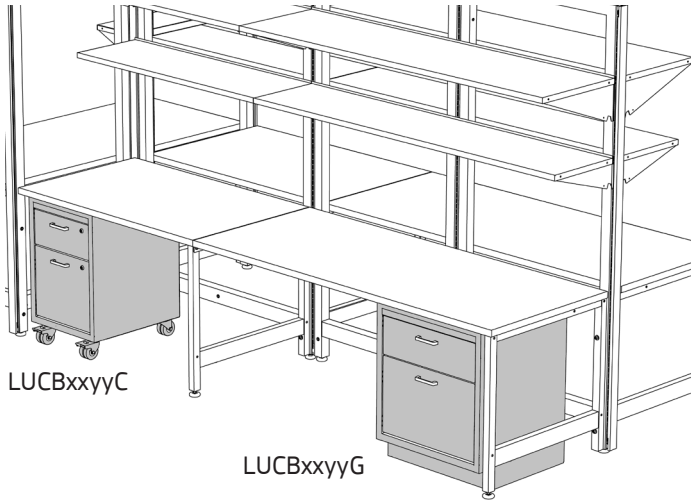

BASE CABINETS, SITTING HEIGHT, DOUBLE DRAWER

- Built to SEFA standards, Cabinets are constructed of welded 18 and 20 gauge steel with a chemical resistant epoxy powder coat paint finish.
- Drawers have full-extension ball bearing, plated drawer slides.
- Sound deadened drawers have "double pan" construction with a bar pull.
- Available with or without locks. Locking cabinets with multiple doors/drawers per unit will have the same key number per unit. Individual units will be keyed randomly and differently from the other. Contact factory for other keying options. Available key numbers are LL226 thru LL327.
- Mobile units have a solid steel top and back with two front total lock casters and two rear swivel casters.
- Stationary units are open on top, contain a removable back panel and include leveling glides.

NOTES

- » Base cabinets can be used in conjunction with UltraFrame, Lab Legs and support brackets; see pages 2.2 - 2.3 and 10.25 - 10.27.
- » Double drawer unit is only available in sitting height (29" high).
- » Recessed pulls available; consult factory.

How to Specify

Step 1. Product Number

LUCB Base Cabinet

Step 2. Height

29 29" high

Step 3. Width

18 18" wide 24 24" wide

Step 4. Glide or Casters

G Glide C Casters

Step 5. Drawer, Pull Type

20B Double Drawer, Bar

Step 6. Locking/Non-Locking

N Non-Locking L Locking

Step 7. Paint Color Code

BK Black
 GL Grey Light Smooth
 NW Neutral White

| Product Number | Description | Height | | Width | | Depth | | Weight | |
|----------------|--------------------------------------|--------|------|-------|------|--------|------|--------|------|
| | | in. | [mm] | in. | [mm] | in. | [mm] | lb. | [kg] |
| LUCB2918G20BN | Sitting height, glides, non-locking | 29 | 737 | 18 | 457 | 21 7/8 | 556 | 95 | 43.1 |
| LUCB2924G20BN | Sitting height, glides, non-locking | 29 | 737 | 24 | 610 | 21 7/8 | 556 | 105 | 47.6 |
| LUCB2918G20BL | Sitting height, glides, locking | 29 | 737 | 18 | 457 | 21 7/8 | 556 | 95 | 43.1 |
| LUCB2924G20BL | Sitting height, glides, locking | 29 | 737 | 24 | 610 | 21 7/8 | 556 | 105 | 47.6 |
| LUCB2918C20BN | Sitting height, casters, non-locking | 29 | 737 | 18 | 457 | 21 7/8 | 556 | 101 | 45.8 |
| LUCB2924C20BN | Sitting height, casters, non-locking | 29 | 737 | 24 | 610 | 21 7/8 | 556 | 111 | 50.3 |
| LUCB2918C20BL | Sitting height, casters, locking | 29 | 737 | 18 | 457 | 21 7/8 | 556 | 101 | 45.8 |
| LUCB2924C20BL | Sitting height, casters, locking | 29 | 737 | 24 | 610 | 21 7/8 | 556 | 111 | 50.3 |

Rev 01/16/20

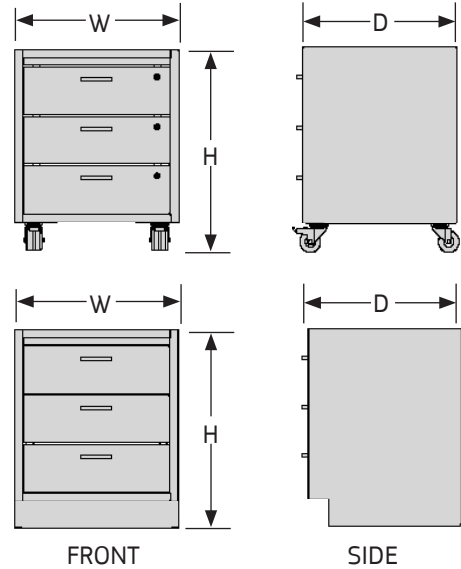
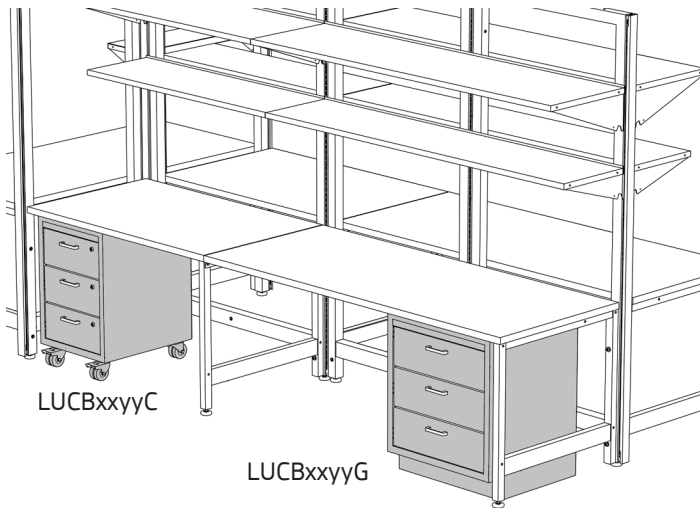

BASE CABINETS, SITTING HEIGHT, 3-DRAWER

- Built to SEFA standards, Cabinets are constructed of welded 18 and 20 gauge steel with a chemical resistant epoxy powder coat paint finish.
- Drawers have full-extension ball bearing, plated drawer slides.
- Sound deadened drawers have "double pan" construction with a bar pull.
- Available with or without locks. Locking cabinets with multiple doors/drawers per unit will have the same key number per unit. Individual units will be keyed randomly and differently from the other. Contact factory for other keying options. Available key numbers are LL226 thru LL327.
- Mobile units have a solid steel top and back with two front total lock casters and two rear swivel casters.
- Stationary units are open on top, contain a removable back panel and include leveling glides.

NOTES

- » Base cabinets can be used in conjunction with UltraFrame, Lab Legs and support brackets; see pages 2.2 - 2.3 and 10.25 - 10.27.
- » Recessed pulls available; consult factory.

How to Specify

Step 1. Product Number

LUCB Base Cabinet

Step 2. Height

29 29" high

Step 3. Width

18 18" wide 24 24" wide

Step 4. Glide or Casters

G Glide C Casters

Step 5. Drawer, Pull Type

30B 3-Drawer, Bar

Step 6. Locking/Non-Locking

N Non-Locking L Locking

Step 7. Paint Color Code

BK Black

GL Grey Light Smooth

NW Neutral White

| Product Number | Description | Height | | Width | | Depth | | Weight | |
|----------------|--------------------------------------|--------|------|-------|------|--------|------|--------|------|
| | | in. | [mm] | in. | [mm] | in. | [mm] | lb. | [kg] |
| LUCB2918G30BN | Sitting height, glides, non-locking | 29 | 737 | 18 | 457 | 21 7/8 | 556 | 95 | 43.1 |
| LUCB2924G30BN | Sitting height, glides, non-locking | 29 | 737 | 24 | 610 | 21 7/8 | 556 | 110 | 49.9 |
| LUCB2918G30BL | Sitting height, glides, locking | 29 | 737 | 18 | 457 | 21 7/8 | 556 | 95 | 43.1 |
| LUCB2924G30BL | Sitting height, glides, locking | 29 | 737 | 24 | 610 | 21 7/8 | 556 | 110 | 49.9 |
| LUCB2918C30BN | Sitting height, casters, non-locking | 29 | 737 | 18 | 457 | 21 7/8 | 556 | 101 | 45.8 |
| LUCB2924C30BN | Sitting height, casters, non-locking | 29 | 737 | 24 | 610 | 21 7/8 | 556 | 116 | 52.6 |
| LUCB2918C30BL | Sitting height, casters, locking | 29 | 737 | 18 | 457 | 21 7/8 | 556 | 101 | 45.8 |
| LUCB2924C30BL | Sitting height, casters, locking | 29 | 737 | 24 | 610 | 21 7/8 | 556 | 116 | 52.6 |

Rev 01/16/20

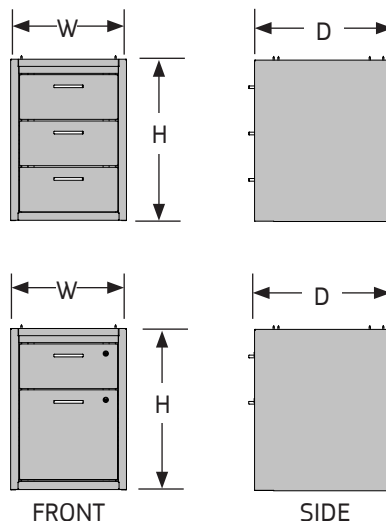
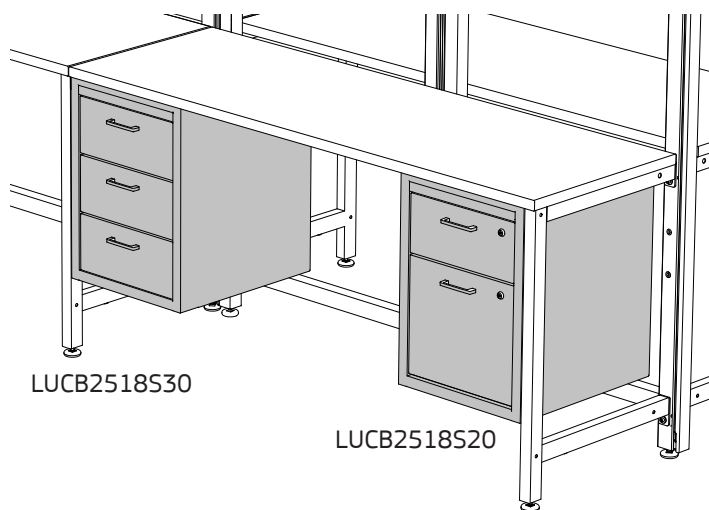

SUSPENDED BASE CABINETS, DRAWERS

- Suspended Base Cabinets can be hung from the underside of surfaces and 4-Legged Table Cabinet Mounting Brackets.
- Built to SEFA standards, Cabinets are constructed of welded 18 and 20 gauge steel with a chemical resistant epoxy powder coat paint finish.
- Drawers have full-extension ball bearing, plated drawer slides.
- Sound deadened drawers have "double pan" construction with a bar pull.
- Available with or without locks. Locking cabinets with multiple doors/drawers per unit will have the same key number per unit. Individual units will be keyed randomly and differently from the other. Contact factory for other keying options. Available key numbers are LL226 thru LL327.
- Units are open on top and have a solid steel back panel.

NOTES

- » Load capacity (includes cabinet and content) cannot exceed 500 lbs. Load capacity of the suspended cabinet does not supercede support component load rating.
- » The suspended component(s) reduces the surface load capacity by an amount equal to the suspended component and its contents.
- » Recessed pulls available; consult factory.
- » 4-Legged Table Cabinet Mounting Brackets sold separately; see page 10.16.

How to Specify

Step 1. Product Number

LUCB Base Cabinet

Step 2. Height

25 25" high

Step 3. Width

18 18" wide 24 24" wide

Step 4. Suspended

S Suspended

Step 5. Drawer, Pull Type

30B 3-Drawer, Bar

Step 6. Locking/Non-Locking

N Non-Locking L Locking

Step 7. Paint Color Code

BK Black
GL Grey Light Smooth
NW Neutral White

| Product Number | Description | Height | | Width | | Depth | | Weight | |
|----------------|----------------------------------|--------|------|-------|------|--------|------|--------|------|
| | | in. | [mm] | in. | [mm] | in. | [mm] | lb. | [kg] |
| LUCB2518S30BN | Suspended, 3-drawer, non-locking | 25 | 635 | 18 | 457 | 21 7/8 | 556 | 81 | 36.7 |
| LUCB2524S30BN | Suspended, 3-drawer, non-locking | 25 | 635 | 24 | 610 | 21 7/8 | 556 | 91 | 41.3 |
| LUCB2518S30BL | Suspended, 3-drawer, locking | 25 | 635 | 18 | 457 | 21 7/8 | 556 | 81 | 36.7 |
| LUCB2524S30BL | Suspended, 3-drawer, locking | 25 | 635 | 24 | 610 | 21 7/8 | 556 | 91 | 41.3 |
| LUCB2518S20BN | Suspended, 2-drawer, non-locking | 25 | 635 | 18 | 457 | 21 7/8 | 556 | 81 | 36.7 |
| LUCB2524S20BN | Suspended, 2-drawer, non-locking | 25 | 635 | 24 | 610 | 21 7/8 | 556 | 91 | 41.3 |
| LUCB2518S20BL | Suspended, 2-drawer, locking | 25 | 635 | 18 | 457 | 21 7/8 | 556 | 81 | 36.7 |
| LUCB2524S20BL | Suspended, 2-drawer, locking | 25 | 635 | 24 | 610 | 21 7/8 | 556 | 91 | 41.3 |

Rev 01/16/20

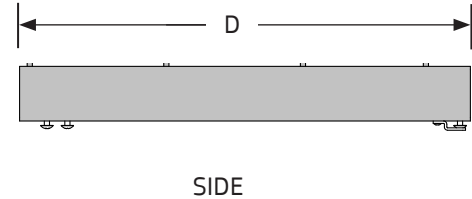
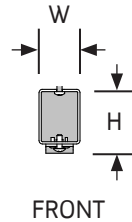
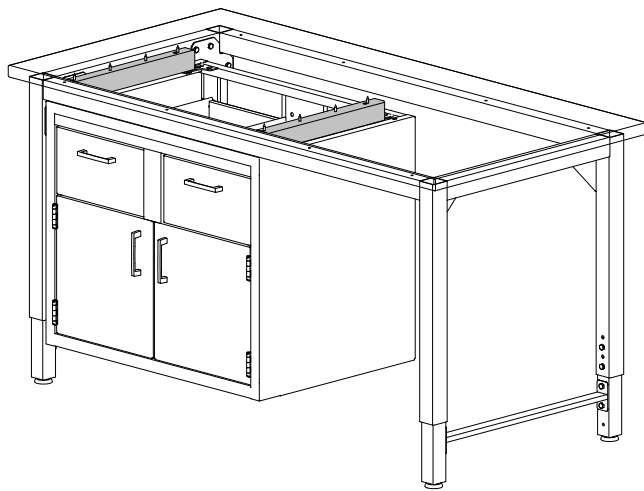

4-LEGGED TABLE CABINET MOUNTING BRACKETS

- 4-Legged Table Cabinet Mounting Brackets allow suspended Base Cabinets to be mounted to a work surface on the 4-Legged Table.
- 4-Legged Table, Work Surface, Cabinet and Mounting Brackets must be ordered individually.
- Mounting Brackets are used with 25" high Base Cabinets which vary in width from 18-48 inches.
- Color is Standard White.

NOTES

- » Load capacity (includes cabinet and content) cannot exceed 500 lbs. Load capacity of the suspended cabinet does not supercede support component load rating.
- » The suspended component(s) reduces the surface load capacity by an amount equal to the suspended component and its contents.
- » Recessed pulls available; consult factory.

How to Specify

Step 1. Product Number

LUCB Base Cabinet

Step 2. Mounting Bracket

4MB 4-Legged Table

Step 3. Paint Color Code

SW Standard White

| Product Number | Description | Height | | Width | | Depth | | Weight | |
|----------------|------------------------|--------|------|-------|------|-------|------|--------|------|
| | | in. | [mm] | in. | [mm] | in. | [mm] | lb. | [kg] |
| LUCB4MBSW | Mounting bracket, pair | 2 ¾ | 60 | 2 | 51 | 16 ½ | 419 | 5 | 2.3 |

Rev 07/21/15

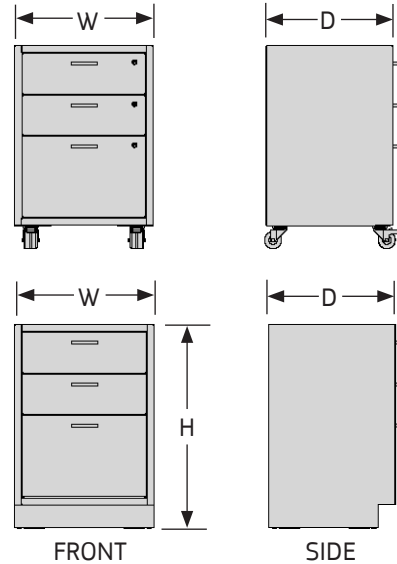
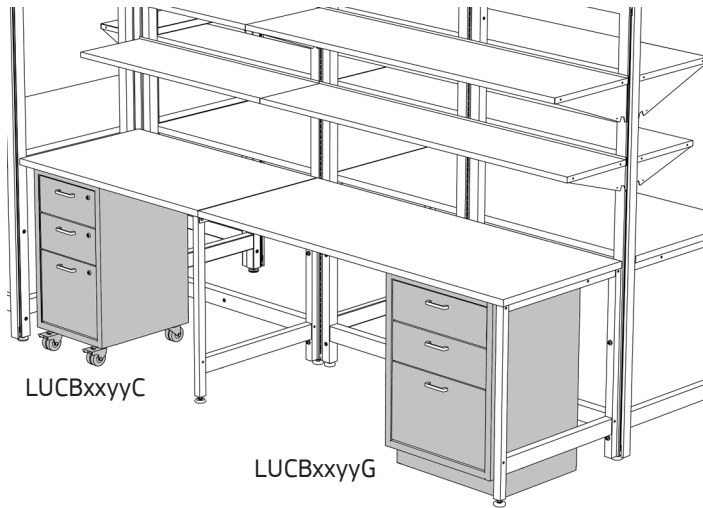

BASE CABINETS, STANDING HEIGHT 3-DRAWER

- Built to SEFA standards, Cabinets are constructed of welded 18 and 20 gauge steel with a chemical resistant epoxy powder coat paint finish.
- Drawers have full-extension ball bearing, plated drawer slides.
- Sound deadened drawers have "double pan" construction with a bar pull.
- Available with or without locks. Locking cabinets with multiple doors/drawers per unit will have the same key number per unit. Individual units will be keyed randomly and differently from the other. Contact factory for other keying options. Available key numbers are LL226 thru LL327.
- Mobile units have a solid steel top and back with two front total lock casters and two rear swivel casters.
- Stationary units are open on top, contain a removable back panel and include leveling glides.

NOTES

- » Base cabinets can be used in conjunction with UltraFrame, Lab Legs and support brackets; see pages 2.2 - 2.3 and 10.25 - 10.27.
- » Recessed pulls available; consult factory.

How to Specify

- Step 1. Product Number**
LUCB Base Cabinet
- Step 2. Height**
35 35" high
- Step 3. Width**
18 18" wide 24 24" wide
- Step 4. Glide or Casters**
G Glide C Casters
- Step 5. Drawer, Pull Type**
30B 3-Drawer, Bar
- Step 6. Locking/Non-Locking**
N Non-Locking L Locking
- Step 7. Paint Color Code**
BK Black
GL Grey Light Smooth
NW Neutral White

| Product Number | Description | Height | | Width | | Depth | | Weight | |
|----------------|---------------------------------------|--------|------|-------|------|--------|------|--------|------|
| | | in. | [mm] | in. | [mm] | in. | [mm] | lb. | [kg] |
| LUCB3518G30BN | Standing height, glides, non-locking | 35 | 889 | 18 | 457 | 21 7/8 | 556 | 110 | 49.9 |
| LUCB3524G30BN | Standing height, glides, non-locking | 35 | 889 | 24 | 610 | 21 7/8 | 556 | 125 | 56.7 |
| LUCB3518G30BL | Standing height, glides, locking | 35 | 889 | 18 | 457 | 21 7/8 | 556 | 110 | 49.9 |
| LUCB3524G30BL | Standing height, glides, locking | 35 | 889 | 24 | 610 | 21 7/8 | 556 | 125 | 56.7 |
| LUCB3518C30BN | Standing height, casters, non-locking | 35 | 889 | 18 | 457 | 21 7/8 | 556 | 116 | 52.6 |
| LUCB3524C30BN | Standing height, casters, non-locking | 35 | 889 | 24 | 610 | 21 7/8 | 556 | 101 | 45.8 |
| LUCB3518C30BL | Standing height, casters, locking | 35 | 889 | 18 | 457 | 21 7/8 | 556 | 116 | 52.6 |
| LUCB3524C30BL | Standing height, casters, locking | 35 | 889 | 24 | 610 | 21 7/8 | 556 | 101 | 45.8 |

Rev 01/16/20

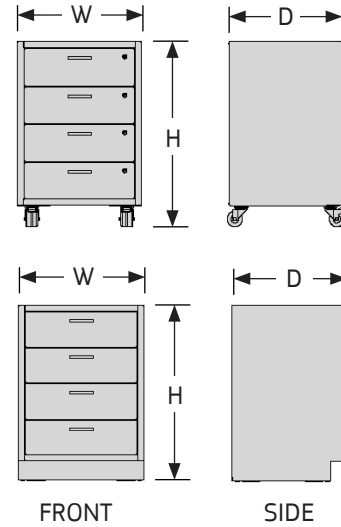
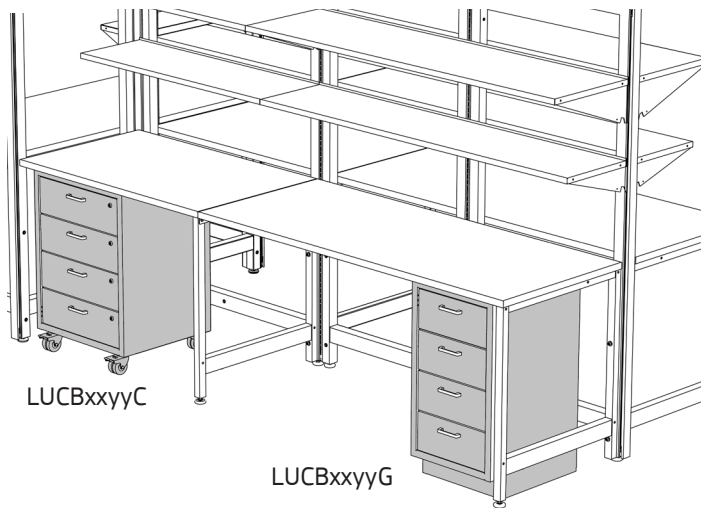

BASE CABINETS, STANDING HEIGHT 4-DRAWER

- Built to SEFA standards, Cabinets are constructed of welded 18 and 20 gauge steel with a chemical resistant epoxy powder coat paint finish.
- Drawers have full-extension ball bearing, plated drawer slides.
- Sound deadened drawers have "double pan" construction with a bar pull.
- Available with or without locks. Locking cabinets with multiple doors/drawers per unit will have the same key number per unit. Individual units will be keyed randomly and differently from the other. Contact factory for other keying options. Available key numbers are LL226 thru LL327.
- Mobile units have a solid steel top and back with two front total lock casters and two rear swivel casters.
- Stationary units are open on top, contain a removable back panel and include leveling glides.

NOTES

- » Base cabinets can be used in conjunction with UltraFrame, Lab Legs and support brackets; see pages 2.2 - 2.3 and 10.25 - 10.27.
- » Recessed pulls available; consult factory.

How to Specify

Step 1. Product Number

LUCB Base Cabinet

Step 2. Height

35 35" high

Step 3. Width

18 18" wide 24 24" wide

Step 4. Glide or Casters

G Glide C Casters

Step 5. Drawer, Pull Type

40B 4-Drawer, Bar

Step 6. Locking/Non-Locking

N Non-Locking L Locking

Step 7. Paint Color Code

BK Black

GL Grey Light Smooth

NW Neutral White

| Product Number | Description | Height | | Width | | Depth | | Weight | |
|----------------|---------------------------------------|--------|------|-------|------|--------|------|--------|------|
| | | in. | [mm] | in. | [mm] | in. | [mm] | lb. | [kg] |
| LUCB3518G40BN | Standing height, glides, non-locking | 35 | 889 | 18 | 457 | 21 7/8 | 556 | 115 | 52.2 |
| LUCB3524G40BN | Standing height, glides, non-locking | 35 | 889 | 24 | 610 | 21 7/8 | 556 | 130 | 59.0 |
| LUCB3518G40BL | Standing height, glides, locking | 35 | 889 | 18 | 457 | 21 7/8 | 556 | 115 | 52.2 |
| LUCB3524G40BL | Standing height, glides, locking | 35 | 889 | 24 | 610 | 21 7/8 | 556 | 130 | 59.0 |
| LUCB3518C40BN | Standing height, casters, non-locking | 35 | 889 | 18 | 457 | 21 7/8 | 556 | 121 | 54.9 |
| LUCB3524C40BN | Standing height, casters, non-locking | 35 | 889 | 24 | 610 | 21 7/8 | 556 | 136 | 61.7 |
| LUCB3518C40BL | Standing height, casters, locking | 35 | 889 | 18 | 457 | 21 7/8 | 556 | 121 | 54.9 |
| LUCB3524C40BL | Standing height, casters, locking | 35 | 889 | 24 | 610 | 21 7/8 | 556 | 136 | 61.7 |

Rev 01/16/20

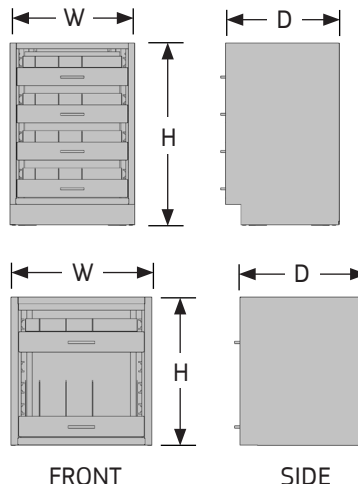
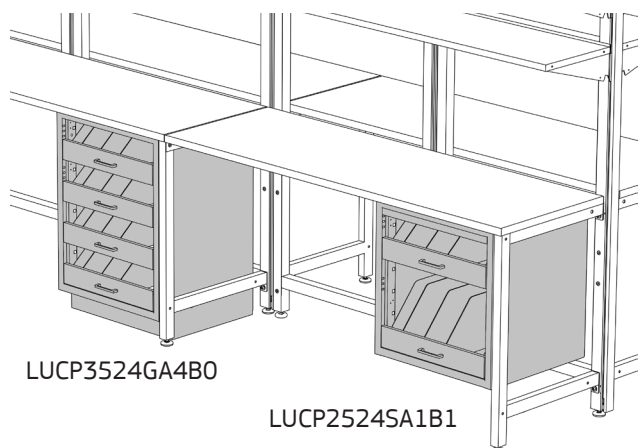

BOTTLE DRAWER CABINETS

- Built to SEFA standards, Cabinets are constructed of welded 18 and 20 gauge steel with a chemical resistant epoxy powder coat paint finish.
- Drawers have full-extension ball bearing, plated drawer slides.
- Suspended bottle drawers can be hung from the underside of surfaces and 4-Legged Tables.
- A-size drawers are 5¼" H and B-size drawers are 9½" H.
- Drawer wrappers, binning strips and 3 drawer dividers provided with each drawer.

NOTES

- » Load capacity is 50 lbs. per drawer.
- » The suspended component(s) reduces the surface load capacity by an amount equal to the suspended component and its contents.
- » Recessed pulls available; consult factory.

How to Specify

Step 1. Product Number

LUCP Bottle Drawer Cabinet

Step 2. Height

25 25" high 29 29" high 35 35" high

Step 3. Width

24 24" wide

Step 4. Suspended or Glide

S Suspended G Glide

Step 5. Drawer Size and Quantity

A0 (0) A-size B0 (0) B-size
 A1 (1) A-size B1 (1) B-size
 A3 (3) A-size B2 (2) B-size
 A4 (4) A-size

Step 6. Paint Color Code

BK Black
 GL Grey Light Smooth
 NW Neutral White

| Product Number | Description | Height | | Width | | Depth | | Weight | |
|----------------|--------------------------|--------|------|-------|------|--------|------|--------|------|
| | | in. | [mm] | in. | [mm] | in. | [mm] | lb. | [kg] |
| LUCP2524SA0B2 | Bottle drawer, suspended | 25 | 635 | 24 | 610 | 21 7/8 | 556 | 107 | 48.5 |
| LUCP2524SA1B1 | Bottle drawer, suspended | 25 | 635 | 24 | 610 | 21 7/8 | 556 | 105 | 47.6 |
| LUCP2524SA3B0 | Bottle drawer, suspended | 25 | 635 | 24 | 610 | 21 7/8 | 556 | 117 | 53.1 |
| LUCP2924GA0B2 | Bottle drawer, glides | 29 | 737 | 24 | 610 | 21 7/8 | 556 | 110 | 49.9 |
| LUCP2924GA1B1 | Bottle drawer, glides | 29 | 737 | 24 | 610 | 21 7/8 | 556 | 108 | 49.0 |
| LUCP2924GA3B0 | Bottle drawer, glides | 29 | 737 | 24 | 610 | 21 7/8 | 556 | 120 | 54.4 |
| LUCP3524GA0B2 | Bottle drawer, glides | 35 | 889 | 24 | 610 | 21 7/8 | 556 | 115 | 52.2 |
| LUCP3524GA1B2 | Bottle drawer, glides | 35 | 889 | 24 | 610 | 21 7/8 | 556 | 130 | 59.0 |
| LUCP3524GA2B1 | Bottle drawer, glides | 35 | 889 | 24 | 610 | 21 7/8 | 556 | 128 | 58.1 |
| LUCP3524GA4B0 | Bottle drawer, glides | 35 | 889 | 24 | 610 | 21 7/8 | 556 | 140 | 63.5 |

Rev 09/22/15

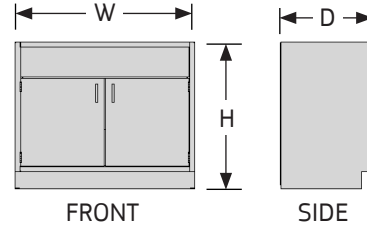
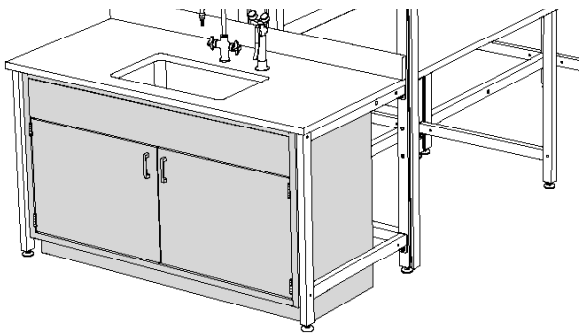

SINK BASE CABINET, STANDARD

- Built to SEFA standards, Cabinets are constructed of welded 18 and 20 gauge steel with a chemical resistant epoxy powder coat paint finish.
- Sound deadened doors have "double pan" construction with a bar pull.
- Doors have 5-knuckle stainless steel institutional type hinges.
- Features a removable bottom pan as well as open upper back for access to plumbing.
- Available with or without locks. Locking cabinets with multiple doors/drawers per unit will have the same key number per unit. Individual units will be keyed randomly and differently from the other. Contact factory for other keying options. Available key numbers are LL226 thru LL327.

NOTES

- » Sink Bases can be used in conjunction with UltraFrame, Lab Legs and support brackets; see pages 2.2 - 2.3 and 10.25 - 10.27.
- » Recessed pulls available; consult factory.

How to Specify

Step 1. Product Number

LUCS Sink Base Cabinet

Step 2. Height

35 35" high

Step 3. Width

18 18" wide 24 24" wide 30 30" wide
 36 36" wide 42 42" wide 48 48" wide
 52 52" wide 58 58" wide

Step 4. Door, Hinge Location, Pull Type

LB Single, Left, Bar RB Single, Right, Bar
 DB Double, Bar

Step 5. Locking/Non-Locking

N Non-Locking L Locking

Step 6. Paint Color Code

BK Black
 GL Grey Light Smooth
 NW Neutral White

| Product Number | Description | Height | | Width | | Depth | | Weight | |
|----------------|--|--------|------|-------|------|--------|------|--------|------|
| | | in. | [mm] | in. | [mm] | in. | [mm] | lb. | [kg] |
| LUCS3518LBN | Left hinged, single door, non-locking | 35 | 889 | 18 | 457 | 21 7/8 | 556 | 75 | 34.0 |
| LUCS3518RBN | Right hinged, single door, non-locking | 35 | 889 | 18 | 457 | 21 7/8 | 556 | 75 | 34.0 |
| LUCS3524LBN | Left hinged, single door, non-locking | 35 | 889 | 24 | 610 | 21 7/8 | 556 | 85 | 38.6 |
| LUCS3524RBN | Right hinged, single door, non-locking | 35 | 889 | 24 | 610 | 21 7/8 | 556 | 85 | 38.6 |
| LUCS3530DBN | Double door, non-locking | 35 | 889 | 30 | 762 | 21 7/8 | 556 | 105 | 47.6 |
| LUCS3536DBN | Double door, non-locking | 35 | 889 | 36 | 914 | 21 7/8 | 556 | 105 | 47.6 |
| LUCS3542DBN | Double door, non-locking | 35 | 889 | 42 | 1067 | 21 7/8 | 556 | 120 | 54.4 |
| LUCS3548DBN | Double door, non-locking | 35 | 889 | 48 | 1219 | 21 7/8 | 556 | 125 | 56.7 |
| LUCS3552DBN | Double door, non-locking | 35 | 889 | 52 | 1321 | 21 7/8 | 556 | 135 | 61.2 |
| LUCS3558DBN | Double door, non-locking | 35 | 889 | 58 | 1473 | 21 7/8 | 556 | 140 | 63.5 |
| LUCS3518LBL | Left hinged, single door, locking | 35 | 889 | 18 | 457 | 21 7/8 | 556 | 75 | 34.0 |
| LUCS3518RBL | Right hinged, single door, locking | 35 | 889 | 18 | 457 | 21 7/8 | 556 | 75 | 34.0 |
| LUCS3524LBL | Left hinged, single door, locking | 35 | 889 | 24 | 610 | 21 7/8 | 556 | 85 | 38.6 |
| LUCS3524RBL | Right hinged, single door, locking | 35 | 889 | 24 | 610 | 21 7/8 | 556 | 85 | 38.6 |
| LUCS3530DBL | Double door, locking | 35 | 889 | 30 | 762 | 21 7/8 | 556 | 105 | 47.6 |
| LUCS3536DBL | Double door, locking | 35 | 889 | 36 | 914 | 21 7/8 | 556 | 105 | 47.6 |
| LUCS3542DBL | Double door, locking | 35 | 889 | 42 | 1067 | 21 7/8 | 556 | 120 | 54.4 |
| LUCS3548DBL | Double door, locking | 35 | 889 | 48 | 1219 | 21 7/8 | 556 | 125 | 56.7 |
| LUCS3552DBL | Double door, locking | 35 | 889 | 52 | 1321 | 21 7/8 | 556 | 135 | 61.2 |
| LUCS3558DBL | Double door, locking | 35 | 889 | 58 | 1473 | 21 7/8 | 556 | 140 | 63.5 |

Rev 01/16/20

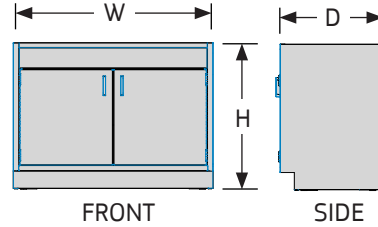
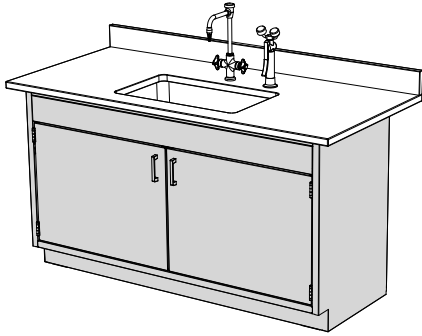

SINK BASE CABINET, ADA, STANDARD

- Built to SEFA standards, Cabinets meet ADA height requirements and are constructed of welded 18 and 20 gauge steel with a chemical resistant epoxy powder coat paint finish.
- Sound deadened doors have "double pan" construction with a bar pull.
- Doors have 5-knuckle stainless steel institutional type hinges.
- Features a removable bottom pan as well as open upper back for access to plumbing.
- Available with or without locks. Locking cabinets with multiple doors/drawers per unit will have the same key number per unit. Individual units will be keyed randomly and differently from the other. Contact factory for other keying options. Available key numbers are LL226 thru LL327.

NOTES

- » Sink Bases can be used in conjunction with UltraFrame, Lab Legs and support brackets; see pages 2.2 - 2.3 and 10.27 - 10.29.
- » Recessed pulls available; consult factory.

How to Specify

Step 1. Product Number

LUCS Sink Base Cabinet, ADA, Standard

Step 2. Height

35 35" high

Step 3. Width

18 18" wide 24 24" wide 30 30" wide
 36 36" wide 42 42" wide 48 48" wide
 52 52" wide 58 58" wide

Step 4. Door, Hinge Location, Pull Type

LB Single, Left, Bar RB Single, Right, Bar
 DB Double, Bar

Step 5. Locking/Non-Locking

N Non-Locking L Locking

Step 6. Paint Color Code

BK Black
 GL Grey Light Smooth
 NW Neutral White

| Product Number | Description | Height | | Width | | Depth | | Weight | |
|----------------|--|--------|------|-------|------|--------|------|--------|------|
| | | in. | [mm] | in. | [mm] | in. | [mm] | lb. | [kg] |
| LUCS3318LBN | Left hinged, single door, non-locking | 33 | 838 | 18 | 457 | 21 7/8 | 556 | 75 | 34 |
| LUCS3318RBN | Right hinged, single door, non-locking | 33 | 838 | 18 | 457 | 21 7/8 | 556 | 75 | 34 |
| LUCS3324LBN | Left hinged, single door, non-locking | 33 | 838 | 24 | 610 | 21 7/8 | 556 | 85 | 39 |
| LUCS3324RBN | Right hinged, single door, non-locking | 33 | 838 | 24 | 610 | 21 7/8 | 556 | 85 | 39 |
| LUCS3330DBN | Double door, non-locking | 33 | 838 | 30 | 762 | 21 7/8 | 556 | 105 | 48 |
| LUCS3336DBN | Double door, non-locking | 33 | 838 | 36 | 914 | 21 7/8 | 556 | 110 | 50 |
| LUCS3342DBN | Double door, non-locking | 33 | 838 | 42 | 1067 | 21 7/8 | 556 | 120 | 54 |
| LUCS3348DBN | Double door, non-locking | 33 | 838 | 48 | 1219 | 21 7/8 | 556 | 125 | 57 |
| LUCS3352DBN | Double door, non-locking | 33 | 838 | 52 | 1321 | 21 7/8 | 556 | 140 | 64 |
| LUCS3358DBN | Double door, non-locking | 33 | 838 | 58 | 1473 | 21 7/8 | 556 | 175 | 79 |
| LUCS3318LBL | Left hinged, single door, locking | 33 | 838 | 18 | 457 | 21 7/8 | 556 | 75 | 34 |
| LUCS3318RBL | Right hinged, single door, locking | 33 | 838 | 18 | 457 | 21 7/8 | 556 | 75 | 34 |
| LUCS3324LBL | Left hinged, single door, locking | 33 | 838 | 24 | 610 | 21 7/8 | 556 | 85 | 39 |
| LUCS3324RBL | Right hinged, single door, locking | 33 | 838 | 24 | 610 | 21 7/8 | 556 | 85 | 39 |
| LUCS3330DBL | Double door, locking | 33 | 838 | 30 | 762 | 21 7/8 | 556 | 105 | 48 |
| LUCS3336DBL | Double door, locking | 33 | 838 | 36 | 914 | 21 7/8 | 556 | 110 | 50 |
| LUCS3342DBL | Double door, locking | 33 | 838 | 42 | 1067 | 21 7/8 | 556 | 120 | 54 |
| LUCS3348DBL | Double door, locking | 33 | 838 | 48 | 1219 | 21 7/8 | 556 | 125 | 57 |
| LUCS3352DBL | Double door, locking | 33 | 838 | 52 | 1321 | 21 7/8 | 556 | 140 | 64 |
| LUCS3358DBL | Double door, locking | 33 | 838 | 58 | 1473 | 21 7/8 | 556 | 175 | 79 |

Rev 03/12/20

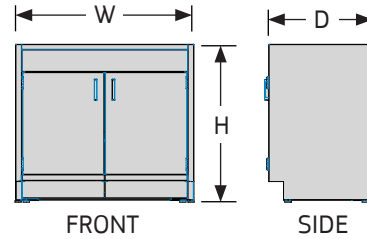
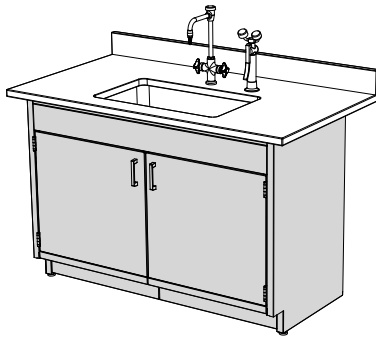

SINK BASE CABINET, ADA, DOOR TO FLOOR

- Built to SEFA standards, Cabinets meet ADA height requirements and are constructed of welded 18 and 20 gauge steel with a chemical resistant epoxy powder coat paint finish.
- Sound deadened doors have "double pan" construction with a bar pull.
- Doors have 5-knuckle stainless steel institutional type hinges.
- Door to floor ADA Sink Base Cabinet door opening includes a integrated toe kick (opens with door).

NOTES

- » Sink Bases can be used in conjunction with UltraFrame, Lab Legs and support brackets; see pages 2.2 - 2.3 and 10.27 - 10.29.
- » Recessed pulls available; consult factory.

How to Specify

Step 1. Product Number

LUCA Sink Base Cabinet, ADA, Door to Floor

Step 2. Height

33 33" high

Step 3. Width

30 30" wide 36 36" wide 42 42" wide
48 48" wide

Step 4. Door, Hinge Location, Pull Type

LB Single, Left, Bar RB Single, Right, Bar
DB Double, Bar

Step 5. Locking/Non-Locking

N Non-Locking

Step 6. Paint Color Code

BK Black
GL Grey Light Smooth
NW Neutral White

| Product Number | Description | Height | | Width | | Depth | | Weight | |
|----------------|--------------------------|--------|------|-------|------|--------|------|--------|------|
| | | in. | [mm] | in. | [mm] | in. | [mm] | lb. | [kg] |
| LUCA3330DBN | Double door, non-locking | 33 | 838 | 30 | 762 | 21 7/8 | 556 | 105 | 48 |
| LUCA3336DBN | Double door, non-locking | 33 | 838 | 36 | 914 | 21 7/8 | 556 | 110 | 50 |
| LUCA3342DBN | Double door, non-locking | 33 | 838 | 42 | 1067 | 21 7/8 | 556 | 120 | 54 |
| LUCA3348DBN | Double door, non-locking | 33 | 838 | 48 | 1219 | 21 7/8 | 556 | 125 | 57 |

Rev 03/12/20

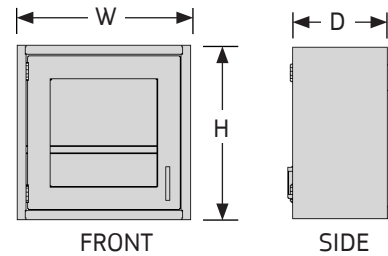
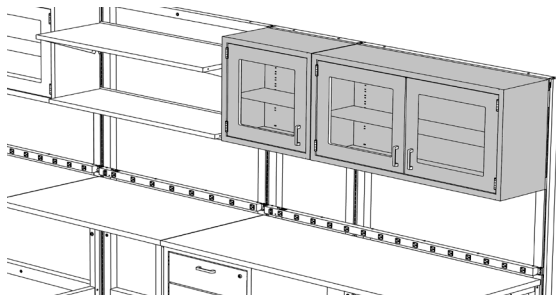

WALL CASES, GLASS DOORS

- Built to SEFA standards, Cabinets are constructed of welded 18 and 20 gauge steel with a chemical resistant epoxy powder coat paint finish.
- Single or double glass doors are available with or without locks.
- A single full depth adjustable shelf is included with each 24" high cabinet and two shelves are included with each 30" high cabinet.
- Sound deadened doors have "double pan" construction with a bar pull.
- Doors have 5-knuckle stainless steel institutional type hinges.
- All standard wall cases are 13" deep.
- Wall cases include the necessary hardware for mounting to either UltraFrames, Wall Strips or directly to a wall.
- Available with or without locks. Locking cabinets with multiple doors/drawers per unit will have the same key number per unit. Individual units will be keyed randomly and differently from the other. Contact factory for other keying options. Available key numbers are LL226 thru LL327.

NOTES

» Additional shelves, 16" cabinet depth and recessed pulls available; consult factory.

How to Specify

Step 1. Product Number

LUCW Wall Cabinet

Step 2. Height

24 24" high 30 30" high

Step 3. Width

24 24" wide 30 30" wide 36 36" wide
48 48" wide

Step 4. Glass Door, Hinge Location, Pull Type

GLB Single, Left, Bar GRB Single, Right, Bar
GDB Double, Bar

Step 5. Locking/Non-Locking

N Non-Locking L Locking

Step 6. Paint Color Code

BK Black GL Grey Light Smooth
NW Neutral White

| Product Number | Description | Height | | Width | | Depth | | Weight | |
|----------------|--|--------|------|-------|------|-------|------|--------|------|
| | | in. | [mm] | in. | [mm] | in. | [mm] | lb. | [kg] |
| LUCW2424GLBN | Left hinged, single door, non-locking | 24 | 610 | 24 | 610 | 13 | 330 | 55 | 24.9 |
| LUCW2424GRBN | Right hinged, single door, non-locking | 24 | 610 | 24 | 610 | 13 | 330 | 55 | 24.9 |
| LUCW2430GDBN | Double door, non-locking | 24 | 610 | 30 | 762 | 13 | 330 | 70 | 31.8 |
| LUCW2436GDBN | Double door, non-locking | 24 | 610 | 36 | 914 | 13 | 330 | 80 | 36.3 |
| LUCW2448GDBN | Double door, non-locking | 24 | 610 | 48 | 1219 | 13 | 330 | 100 | 45.4 |
| LUCW3024GLBN | Left hinged, single door, non-locking | 31 | 787 | 24 | 610 | 13 | 330 | 70 | 31.8 |
| LUCW3024GRBN | Right hinged, single door, non-locking | 31 | 787 | 24 | 610 | 13 | 330 | 70 | 31.8 |
| LUCW3030GDBN | Double door, non-locking | 31 | 787 | 30 | 762 | 13 | 330 | 85 | 38.6 |
| LUCW3036GDBN | Double door, non-locking | 31 | 787 | 36 | 914 | 13 | 330 | 95 | 43.1 |
| LUCW3048GDBN | Double door, non-locking | 31 | 787 | 48 | 1219 | 13 | 330 | 125 | 56.7 |
| LUCW2424GLBL | Left hinged, single door, locking | 24 | 610 | 24 | 610 | 13 | 330 | 55 | 24.9 |
| LUCW2424GRBL | Right hinged, single door, locking | 24 | 610 | 24 | 610 | 13 | 330 | 55 | 24.9 |
| LUCW2430GDBL | Double door, locking | 24 | 610 | 30 | 762 | 13 | 330 | 70 | 31.8 |
| LUCW2436GDBL | Double door, locking | 24 | 610 | 36 | 914 | 13 | 330 | 80 | 36.3 |
| LUCW2448GDBL | Double door, locking | 24 | 610 | 48 | 1219 | 13 | 330 | 100 | 45.4 |
| LUCW3024GLBL | Left hinged, single door, locking | 31 | 787 | 24 | 610 | 13 | 330 | 70 | 31.8 |
| LUCW3024GRBL | Right hinged, single door, locking | 31 | 787 | 24 | 610 | 13 | 330 | 70 | 31.8 |
| LUCW3030GDBL | Double door, locking | 31 | 787 | 30 | 762 | 13 | 330 | 85 | 38.6 |
| LUCW3036GDBL | Double door, locking | 31 | 787 | 36 | 914 | 13 | 330 | 95 | 43.1 |
| LUCW3048GDBL | Double door, locking | 31 | 787 | 48 | 1219 | 13 | 330 | 125 | 56.7 |

Rev 01/16/20

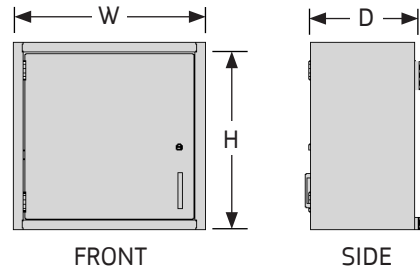
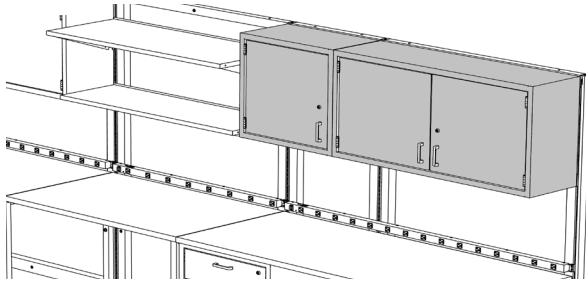

WALL CASES, SOLID DOORS

- Built to SEFA standards, Cabinets are constructed of welded 18 and 20 gauge steel with a chemical resistant epoxy powder coat paint finish.
- Single or double glass doors are available with or without locks.
- A single full depth adjustable shelf is included with each 24" high cabinet and two shelves are included with each 30" high cabinet.
- Sound deadened doors have "double pan" construction with a bar pull.
- Doors have 5-knuckle stainless steel institutional type hinges.
- All standard wall cases are 13" deep.
- Wall cases include the necessary hardware for mounting to either UltraFrames, Wall Strips or directly to a wall.
- Available with or without locks. Locking cabinets with multiple doors/drawers per unit will have the same key number per unit. Individual units will be keyed randomly and differently from the other. Contact factory for other keying options. Available key numbers are LL226 thru LL327.

NOTES

- » Additional shelves, 16" cabinet depth and recessed pulls available; consult factory.

How to Specify

Step 1. Product Number

LUCW Wall Case

Step 2. Height

24 24" high 30 30" high

Step 3. Width

24 24" wide 30 30" wide 36 36" wide
48 48" wide

Step 4. Solid Door, Hinge Location, Pull Type

SLB Single, Left, Bar SRB Single, Right, Bar
SDB Double, Bar

Step 5. Locking/Non-Locking

N Non-Locking L Locking

Step 6. Paint Color Code

BK Black GL Grey Light Smooth
NW Neutral White

| Product Number | Description | Height | | Width | | Depth | | Weight | |
|----------------|--|--------|------|-------|------|-------|------|--------|------|
| | | in. | [mm] | in. | [mm] | in. | [mm] | lb. | [kg] |
| LUCW2424SLBN | Left hinged, single door, non-locking | 24 | 610 | 24 | 610 | 13 | 330 | 55 | 24.9 |
| LUCW2424SRBN | Right hinged, single door, non-locking | 24 | 610 | 24 | 610 | 13 | 330 | 55 | 24.9 |
| LUCW2430SDBN | Double door, non-locking | 24 | 610 | 30 | 762 | 13 | 330 | 70 | 31.8 |
| LUCW2436SDBN | Double door, non-locking | 24 | 610 | 36 | 914 | 13 | 330 | 80 | 36.3 |
| LUCW2448SDBN | Double door, non-locking | 24 | 610 | 48 | 1219 | 13 | 330 | 100 | 45.4 |
| LUCW3024SLBN | Left hinged, single door, non-locking | 31 | 787 | 24 | 610 | 13 | 330 | 70 | 31.8 |
| LUCW3024SRBN | Right hinged, single door, non-locking | 31 | 787 | 24 | 610 | 13 | 330 | 70 | 31.8 |
| LUCW3030SDBN | Double door, non-locking | 31 | 787 | 30 | 762 | 13 | 330 | 85 | 38.6 |
| LUCW3036SDBN | Double door, non-locking | 31 | 787 | 36 | 914 | 13 | 330 | 95 | 43.1 |
| LUCW3048SDBN | Double door, non-locking | 31 | 787 | 48 | 1219 | 13 | 330 | 125 | 56.7 |
| LUCW2424SLBL | Left hinged, single door, locking | 24 | 610 | 24 | 610 | 13 | 330 | 55 | 24.9 |
| LUCW2424SRBL | Right hinged, single door, locking | 24 | 610 | 24 | 610 | 13 | 330 | 55 | 24.9 |
| LUCW2430SDBL | Double door, locking | 24 | 610 | 30 | 762 | 13 | 330 | 70 | 31.8 |
| LUCW2436SDBL | Double door, locking | 24 | 610 | 36 | 914 | 13 | 330 | 80 | 36.3 |
| LUCW2448SDBL | Double door, locking | 24 | 610 | 48 | 1219 | 13 | 330 | 100 | 45.4 |
| LUCW3024SLBL | Left hinged, single door, locking | 31 | 787 | 24 | 610 | 13 | 330 | 70 | 31.8 |
| LUCW3024SRBL | Right hinged, single door, locking | 31 | 787 | 24 | 610 | 13 | 330 | 70 | 31.8 |
| LUCW3030SDBL | Double door, locking | 31 | 787 | 30 | 762 | 13 | 330 | 85 | 38.6 |
| LUCW3036SDBL | Double door, locking | 31 | 787 | 36 | 914 | 13 | 330 | 95 | 43.1 |
| LUCW3048SDBL | Double door, locking | 31 | 787 | 48 | 1219 | 13 | 330 | 125 | 56.7 |

Rev 01/16/20

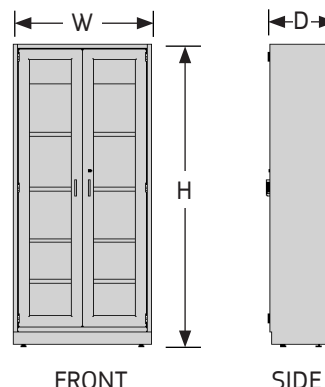
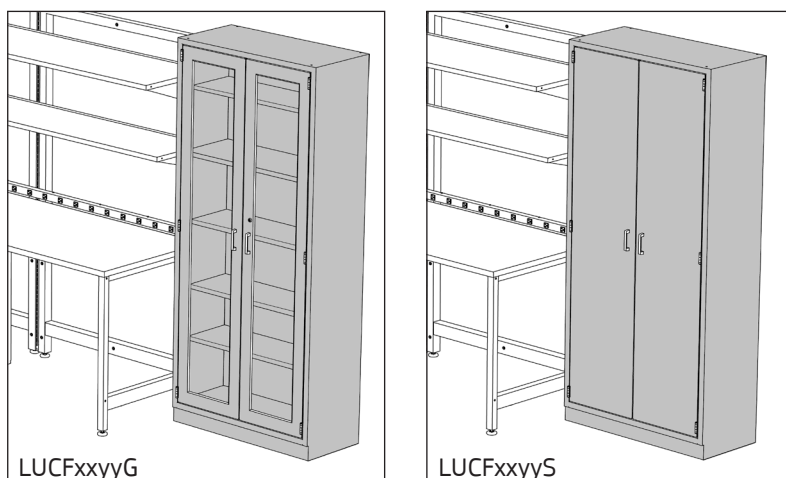

FLOOR CASES

- Built to SEFA standards, Cabinets are constructed of welded 18 and 20 gauge steel with a chemical resistant epoxy powder coat paint finish.
- Solid or glass double doors are available with or without locks.
- Five full depth adjustable shelves are included with each floor case.
- Sound deadened doors have "double pan" construction with a bar pull.
- Doors have 5-knuckle stainless steel institutional type hinges.
- All standard floor cases are 16" deep.
- Available with or without locks. Locking cabinets with multiple doors/drawers per unit will have the same key number per unit. Individual units will be keyed randomly and differently from the other. Contact factory for other keying options. Available key numbers are LL226 thru LL327.

NOTES

- » Floor cases are free-standing and not intended to attach to a frame.
- » Floor cases must be secured to a wall or otherwise supported vertically.
- » Leveling glides included for stability adjustment.
- » Standard depth is 16", consult factory for pricing on 21¼" deep floor cases.

How to Specify

Step 1. Product Number

LUCF Floor Case

Step 2. Depth

16 16" deep

Step 3. Width

36 36" wide 48 48" wide

Step 4. Door Type, Pull Type

SDB Solid, Double, Bar GDB Glass, Double, Bar

Step 5. Locking/Non-Locking

N Non-Locking L Locking

Step 6. Paint Color Code

BK Black
 GL Grey Light Smooth
 NW Neutral White

| Product Number | Description | Height | | Width | | Depth | | Weight | |
|----------------|--------------------------------|--------|------|-------|------|-------|------|--------|-------|
| | | in. | [mm] | in. | [mm] | in. | [mm] | lb. | [kg] |
| LUCF1636SDBN | Double solid door, non-locking | 84 | 2134 | 36 | 914 | 16 | 406 | 300 | 136.1 |
| LUCF1636GDBN | Double glass door, non-locking | 84 | 2134 | 36 | 914 | 16 | 406 | 305 | 138.3 |
| LUCF1648SDBN | Double solid door, non-locking | 84 | 2134 | 48 | 1219 | 16 | 406 | 380 | 172.4 |
| LUCF1648GDBN | Double glass door, non-locking | 84 | 2134 | 48 | 1219 | 16 | 406 | 390 | 176.9 |
| LUCF1636SDBL | Double solid door, locking | 84 | 2134 | 36 | 914 | 16 | 406 | 300 | 136.1 |
| LUCF1636GDBL | Double glass door, locking | 84 | 2134 | 36 | 914 | 16 | 406 | 305 | 138.3 |
| LUCF1648SDBL | Double solid door, locking | 84 | 2134 | 48 | 1219 | 16 | 406 | 380 | 172.4 |
| LUCF1648GDBL | Double glass door, locking | 84 | 2134 | 48 | 1219 | 16 | 406 | 390 | 176.9 |

Rev 01/16/20

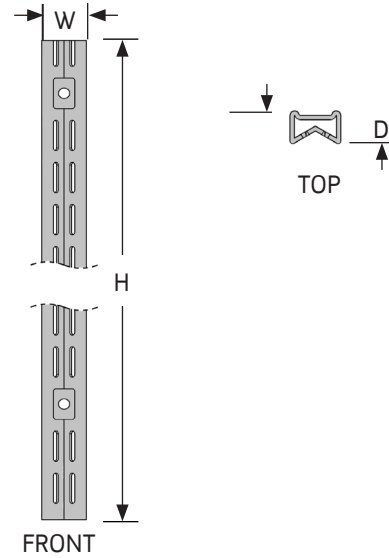
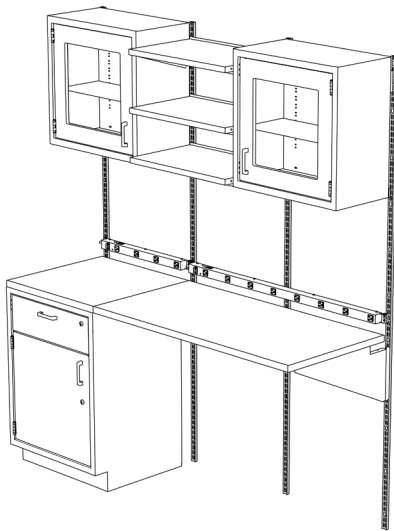

WALL STRIPS

- Sold individually, Wall Strips attach with wall fasteners to a structural wall to support hanging components. Two wall strips are required to hang a component.
- The 60" wall strip requires 8 fasteners; the 72" wall strip requires 9 fasteners; and the 84" wall strip requires 11 fasteners.
- Sold individually, not in pairs.

NOTES

- » Wall fasteners not included; consult factory.

How to Specify

Step 1. Product Number

WS Wall Strip

Step 2. Height

60 60" high 72 72" high 84 84" high

Step 3. Paint Color Code

BK Black

| Product Number | Description | Height | | Width | | Depth | | Weight | |
|----------------|-------------|--------|------|-------|------|-------|------|--------|------|
| | | in. | [mm] | in. | [mm] | in. | [mm] | lb. | [kg] |
| WS60BK | Wall strip | 60 | 1524 | 1 | 25 | ¾ | 19 | 3 | 1.4 |
| WS72BK | Wall strip | 72 | 1829 | 1 | 25 | ¾ | 19 | 3 | 1.4 |
| WS84BK | Wall strip | 84 | 2134 | 1 | 25 | ¾ | 19 | 3 | 1.4 |

Rev 10/12/10

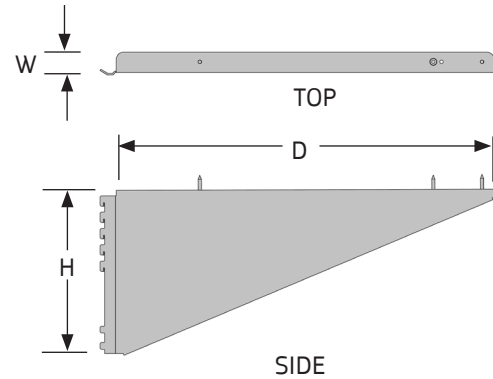
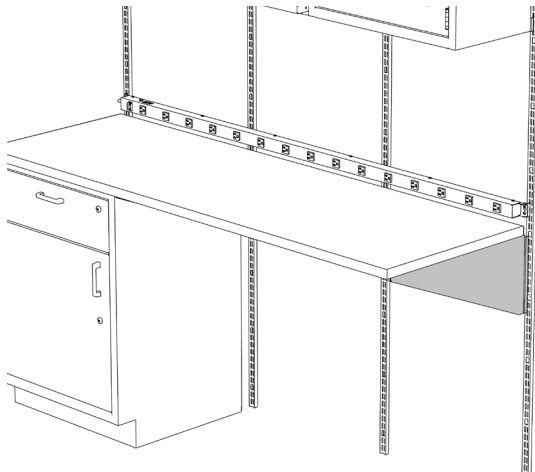

CANTILEVER BRACKETS

- Lab Cantilever Brackets provide manual height adjustable support for 24" and 30" deep work surfaces mounted to UltraFrames supported by Lab Legs.
- Cantilevers also provide mid support for surfaces wider than 60".

NOTES

- » Use 24" cantilevers with 24" and 30" deep surfaces. 36" deep surfaces should be supported with Lab Legs and Adjacent Brackets; see pages 10.27-10.29.
- » 72" and 96" wide frame-mounted surfaces must be supported in the center by Lab Cantilever Brackets. Specify one 18" cantilever per 24" and 30" deep surface and one 24" cantilever per 36" deep surface.
- » Cantilever brackets cannot be used with Lab Reinforcement Bars.

How to Specify

Step 1. Product Number

LUSC Cantilever Bracket

Step 2. Location

L Left R Right

Step 3. Depth

18 18" deep 24 24" deep

Step 4. Paint Color Code

BK Black
 GL Grey Light Smooth
 NW Neutral White

| Product Number | Description | Height | | Width | | Depth | | Weight | |
|----------------|-------------|--------|------|-------|------|-------|------|--------|------|
| | | in. | [mm] | in. | [mm] | in. | [mm] | lb. | [kg] |
| LUSCL18 | Left | 8 ½ | 216 | 1 ¼ | 32 | 18 ¼ | 464 | 4 | 1.8 |
| LUSCR18 | Right | 8 ½ | 216 | 1 ¼ | 32 | 18 ¼ | 464 | 4 | 1.8 |
| LUSCL24 | Left | 10 ½ | 267 | 1 ¼ | 32 | 24 ¼ | 616 | 5 | 2.3 |
| LUSCR24 | Right | 10 ½ | 267 | 1 ¼ | 32 | 24 ¼ | 616 | 5 | 2.3 |

Rev 07/07/10

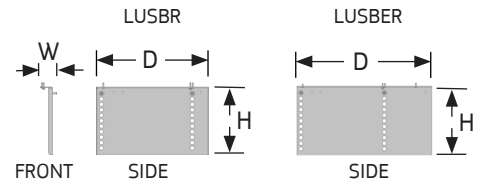
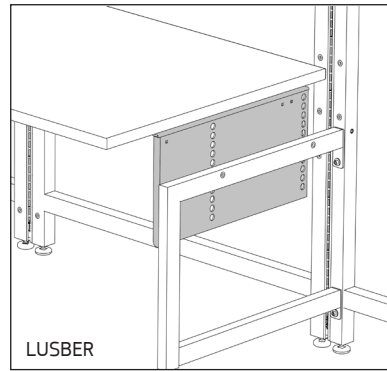
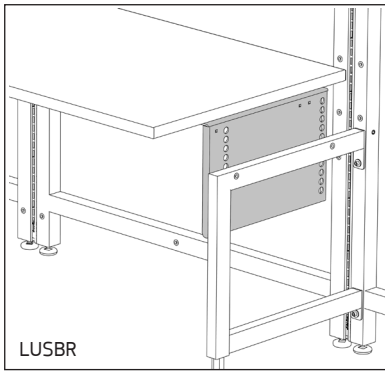

LAB HEIGHT B SUPPORTS

- Brackets provide manual height adjustable support for Ultra or Work Surfaces mounted to C Leg Supports.
- Height range is 26½" to 36½" for CLM and 31½" to 41½" for CLT.
- Lab Height B Supports allow for surface height alignment with Lab Leg mounted surfaces and provide clearance for Base Cabinets at the nominal 29" and 35" bracket heights.
- Extended brackets are for use with 36" deep surfaces, while the 18½" deep brackets are for use with 24" and 30" deep surfaces.

NOTES

- » 72" and 96" frame-mounted surfaces must be supported in the center by Lab Cantilever Brackets. Specify one 18" cantilever per 24" and 30" deep surface and one 24" cantilever per 36" deep surface.

How to Specify

Step 1. Product Number

- LUSB B Support
- LUSBE B Support, extended

Step 2. Location

- L Left
- R Right

Step 3. Adjustment Range

- 10 10" high

Step 4. Paint Color Code

STANDARD

- AW Arctic White
- AS Argent Silver
- BK Black
- BT Black Texture
- GL Grey Light Smooth
- GT Grey Light Texture
- NW Neutral White
- ST Sand Texture

| Product Number | Description | Height | | Width | | Depth | | Weight | |
|----------------|-----------------|--------|------|-------|------|-------|------|--------|------|
| | | in. | [mm] | in. | [mm] | in. | [mm] | lb. | [kg] |
| LUSBL10 | Left | 12 ½ | 318 | 2 ¼ | 57 | 18 ⅝ | 473 | 12 ½ | 5.7 |
| LUSBR10 | Right | 12 ½ | 318 | 2 ¼ | 57 | 18 ⅝ | 473 | 12 ½ | 5.7 |
| LUSBEL10 | Left, extended | 12 ½ | 318 | 2 ¼ | 57 | 24 ⅝ | 625 | 16 ½ | 7.5 |
| LUSBER10 | Right, extended | 12 ½ | 318 | 2 ¼ | 57 | 24 ⅝ | 625 | 16 ½ | 7.5 |

04/01/19

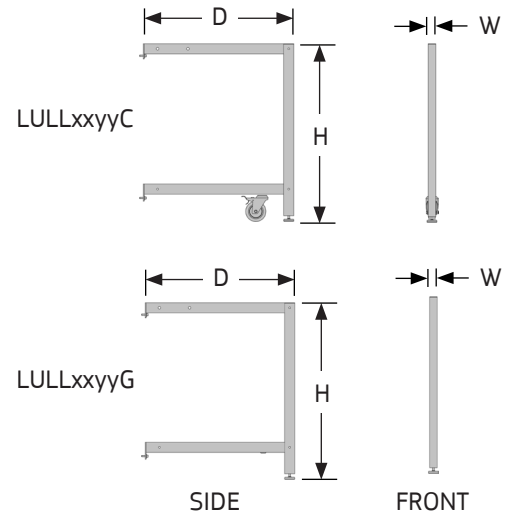
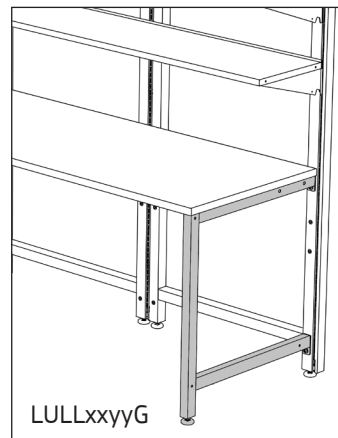
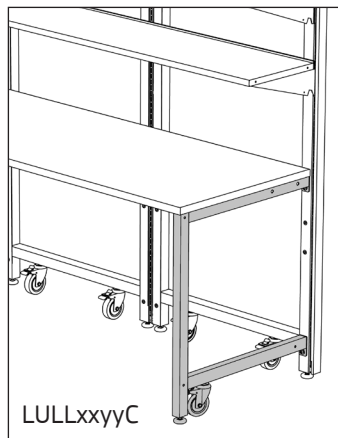

LAB LEGS

- Lab Legs provide standing support for UltraFrames.
- Legs bolt to connection points on both the front and back sides of UltraFrames and Connector Posts (80" high max).
- Legs are each equipped with a leveling glide. Lab Legs with Casters also include a 4" diameter polypropylene caster with totalock brake (simultaneously locks swivel and wheel) and can only be attached to UltraFrames with Casters. Lab legs with Glides bolt to UltraFrames with Glides or Connector Posts.
- Lab Legs cannot be used to support 96" high UltraFrames.
- Surfaces can be mounted directly to the top of Lab Legs mounted inboard of the frame. Outboard mounted Lab Legs require Adjacent Brackets to support the surface.

NOTES

- » The nominal Lab Leg depth must match the nominal surface depth.
- » Adjacent Brackets sold separately; see page 10.28.

How to Specify

Step 1. Product Number

LULL Lab Leg

Step 2. Height

29 29" high 35 35" high

Step 3. Depth

24 24" deep 30 30" deep 36 36" deep

Step 4. Casters or Glide

C Casters G Glide

Step 5. Paint Color Code

BK Black
GL Grey Light Smooth
NW Neutral White

| Product Number | Description | Height | | Width | | Depth | | Weight | |
|----------------|-------------|--------|------|-------|------|-------|------|--------|------|
| | | in. | [mm] | in. | [mm] | in. | [mm] | lb. | [kg] |
| LULL2924C | Caster | 29 | 737 | 1 ½ | 38 | 23 ¾ | 603 | 13 | 5.9 |
| LULL2924G | Glide | 29 | 737 | 1 ½ | 38 | 23 ¾ | 603 | 13 | 5.9 |
| LULL2930C | Caster | 29 | 737 | 1 ½ | 38 | 29 ¾ | 756 | 14 | 6.4 |
| LULL2930G | Glide | 29 | 737 | 1 ½ | 38 | 29 ¾ | 756 | 14 | 6.4 |
| LULL2936C | Caster | 29 | 737 | 1 ½ | 38 | 35 ¾ | 908 | 15 | 6.8 |
| LULL2936G | Glide | 29 | 737 | 1 ½ | 38 | 35 ¾ | 908 | 15 | 6.8 |
| LULL3524C | Caster | 35 | 889 | 1 ½ | 38 | 23 ¾ | 603 | 14 | 6.4 |
| LULL3524G | Glide | 35 | 889 | 1 ½ | 38 | 23 ¾ | 603 | 14 | 6.4 |
| LULL3530C | Caster | 35 | 889 | 1 ½ | 38 | 29 ¾ | 756 | 15 | 6.8 |
| LULL3530G | Glide | 35 | 889 | 1 ½ | 38 | 29 ¾ | 756 | 15 | 6.8 |
| LULL3536C | Caster | 35 | 889 | 1 ½ | 38 | 35 ¾ | 908 | 16 | 7.3 |
| LULL3536G | Glide | 35 | 889 | 1 ½ | 38 | 35 ¾ | 908 | 16 | 7.3 |

Rev 10/20/10

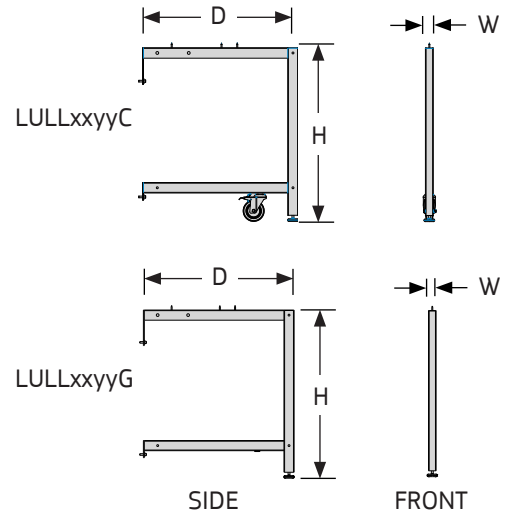
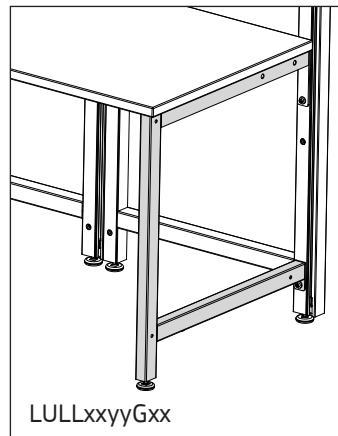
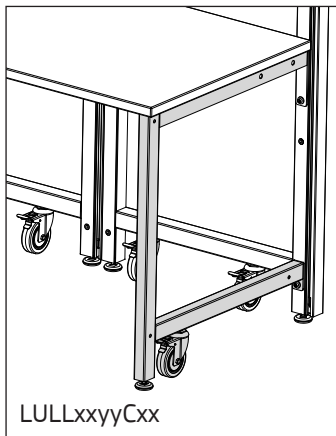

LAB LEGS, ADA

- ADA Lab Legs provide standing support for UltraFrames.
- Legs bolt to connection points on both the front and back sides of UltraFrames and Connector Posts (80" high max).
- Legs are each equipped with a leveling glide. Lab Legs with Casters also include a 4" diameter polypropylene caster with totalock brake (simultaneously locks swivel and wheel) and can only be attached to UltraFrames with Casters. Lab legs with Glides bolt to UltraFrames with Glides or Connector Posts.
- ADA Lab Legs cannot be used to support 96" high UltraFrames.
- Surfaces can be mounted directly to the top of Lab Legs mounted inboard of the frame. Outboard mounted Lab Legs require Adjacent Brackets to support the surface.

NOTES

- » The nominal Lab Leg depth must match the nominal surface depth.
- » Adjacent Brackets sold separately; see page 10.28.

How to Specify

Step 1. Product Number

LULL Lab Leg, ADA

Step 2. Height

33 33" high

Step 3. Depth

24 24" deep 30 30" deep 36 36" deep

Step 4. Casters or Glide

C Casters G Glide

Step 5. Paint Color Code

BK Black
GL Grey Light Smooth
NW Neutral White

| Product Number | Description | Height | | Width | | Depth | | Weight | |
|----------------|-------------|--------|------|-------|------|-------|------|--------|------|
| | | in. | [mm] | in. | [mm] | in. | [mm] | lb. | [kg] |
| LULL3324C | Caster | 33 | 838 | 1 ½ | 38 | 23 ¾ | 603 | 16 | 7.3 |
| LULL3324G | Glide | 33 | 838 | 1 ½ | 38 | 23 ¾ | 603 | 16 | 7.3 |
| LULL3330C | Caster | 33 | 838 | 1 ½ | 38 | 29 ¾ | 756 | 17 | 7.7 |
| LULL3330G | Glide | 33 | 838 | 1 ½ | 38 | 29 ¾ | 756 | 17 | 7.7 |
| LULL3336C | Caster | 33 | 838 | 1 ½ | 38 | 35 ¾ | 908 | 18 | 8.2 |
| LULL3336G | Glide | 33 | 838 | 1 ½ | 38 | 35 ¾ | 908 | 18 | 8.2 |

Rev 08/20/20

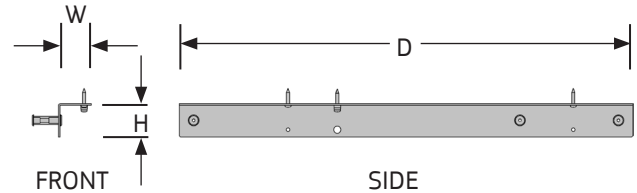
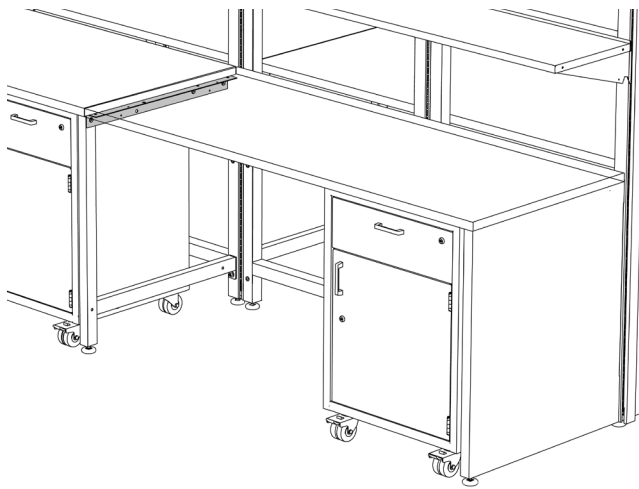

ADJACENT BRACKETS

- Adjacent Brackets provide fixed height support for work surfaces mounted to Lab Legs outboard of the UltraFrame.
- Brackets can be used in conjunction with Lab Leg Panels and Lab Reinforcement Bars.

NOTES

- » Order nominal bracket depth to match surface depth.

How to Specify

Step 1. Product Number

LUSA Adjacent Bracket

Step 2. Depth

24 24" deep 30 30" deep 36 36" deep

Step 3. Paint Color Code

- BK Black
- GL Grey Light Smooth
- NW Neutral White

| Product Number | Description | Height | | Width | | Depth | | Weight | |
|----------------|------------------|--------|------|-------|------|-------|------|--------|------|
| | | in. | [mm] | in. | [mm] | in. | [mm] | lb. | [kg] |
| LUSA24 | Adjacent bracket | 2 | 51 | 2 | 51 | 21 ½ | 546 | 2 | 0.9 |
| LUSA30 | Adjacent bracket | 2 | 51 | 2 | 51 | 27 ½ | 699 | 3 | 1.4 |
| LUSA36 | Adjacent bracket | 2 | 51 | 2 | 51 | 33 ½ | 851 | 3 | 1.4 |

Rev 03/29/10

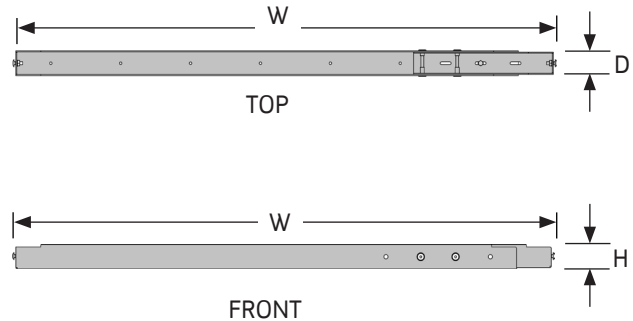
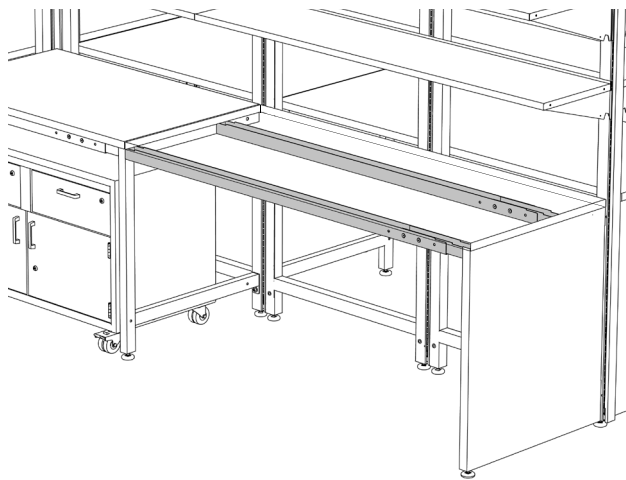

SURFACE REINFORCEMENT BARS

- Lab Reinforcement Bars provide horizontal support under work surfaces for increased rigidity.
- Bars are sold in pairs and mount at the front and 20" behind the front of Lab Legs.
- Bars adjust over a 6" range to accommodate inboard and outboard Lab Legs and Adjacent Bracket clearance.
- Finish is Black.

NOTES

- » Lab Reinforcement Bars cannot be used with Lab Cantilever Brackets.

How to Specify

Step 1. Product Number

LUSR Surface Reinforcement Bars, pair

Step 2. Width

48 48" wide 60 60" wide 72 72" wide

Step 3. Paint Color Code

BK Black

| Product Number | Description | Height | | Width | | Depth | | Weight | |
|----------------|--------------------------|--------|------|--------------|-------------|-------|------|--------|------|
| | | in. | [mm] | in. | [mm] | in. | [mm] | lb. | [kg] |
| LUSR48BK | Reinforcement bars, pair | 2 | 51 | 43 ½ - 49 ½ | 1105 - 1257 | 2 | 51 | 15 | 6.8 |
| LUSR60BK | Reinforcement bars, pair | 2 | 51 | 55 ½ - 61 ½ | 1410 - 1562 | 2 | 51 | 18 | 8.2 |
| LUSR72BK | Reinforcement bars, pair | 2 | 51 | 67 ½ - 73 -½ | 1715 - 1867 | 2 | 51 | 24 | 10.9 |

Rev 10/20/10

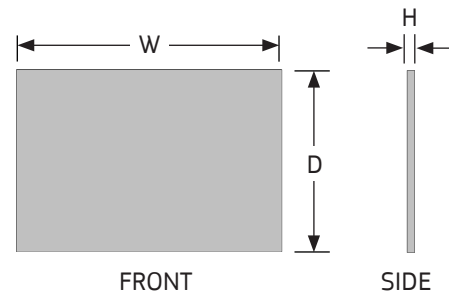
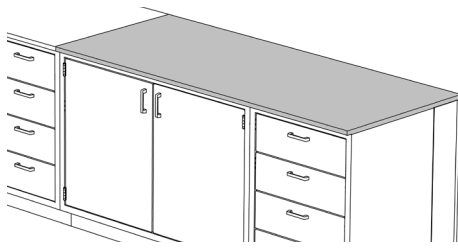

PHENOLIC LAB SURFACES

- 1" high solid Phenolic Lab Surfaces are full width and depth and can be mounted to Base Cabinets and/or surface supports.
- Surfaces have smooth 1/8" radius corners and edges.
- Surfaces are not predrilled, but include a drip groove inset from the front edge of the surface.
- Phenolic resin material is specifically manufactured for highly corrosive environments and provides exceptional chemical and wear resistance. Contact factory for detailed chemical resistance testing data.
- Load capacity 300 lbs. evenly distributed when supported every five feet.
- Finish is Black.

NOTES

- » Mounting hardware is not included; recommended attaching method is silicone adhesive.
- » See Section 4 for Phenolic Backsplash.

How to Specify

Step 1. Product Number

LUTP Phenolic Lab Surface

Step 2. Depth

24 24" deep 30 30" deep 36 36" deep

Step 3. Width

24 24" wide 30 30" wide 36 36" wide
 48 48" wide 60 60" wide 72 72" wide
 96 96" wide 120 120" wide

Step 4. Color Code

BK Black

| Product Number | Description | Height | | Width | | Depth | | Weight | |
|----------------|----------------------|--------|------|-------|------|-------|------|--------|------|
| | | in. | [mm] | in. | [mm] | in. | [mm] | lb. | [kg] |
| LUTP2424BK | Phenolic lab surface | 1 | 25 | 24 | 610 | 24 | 610 | 29 | 13.2 |
| LUTP2430BK | Phenolic lab surface | 1 | 25 | 30 | 762 | 24 | 610 | 36 | 16.3 |
| LUTP2436BK | Phenolic lab surface | 1 | 25 | 36 | 914 | 24 | 610 | 43 | 19.5 |
| LUTP2448BK | Phenolic lab surface | 1 | 25 | 48 | 1219 | 24 | 610 | 58 | 26.3 |
| LUTP2460BK | Phenolic lab surface | 1 | 25 | 60 | 1524 | 24 | 610 | 72 | 32.7 |
| LUTP2472BK | Phenolic lab surface | 1 | 25 | 72 | 1829 | 24 | 610 | 86 | 39.0 |
| LUTP2496BK | Phenolic lab surface | 1 | 25 | 96 | 2438 | 24 | 610 | 115 | 52.2 |
| LUTP24120BK | Phenolic lab surface | 1 | 25 | 120 | 3048 | 24 | 610 | 144 | 65.3 |
| LUTP3024BK | Phenolic lab surface | 1 | 25 | 24 | 610 | 30 | 762 | 36 | 16.3 |
| LUTP3030BK | Phenolic lab surface | 1 | 25 | 30 | 762 | 30 | 762 | 45 | 20.4 |
| LUTP3036BK | Phenolic lab surface | 1 | 25 | 36 | 914 | 30 | 762 | 54 | 24.5 |
| LUTP3048BK | Phenolic lab surface | 1 | 25 | 48 | 1219 | 30 | 762 | 72 | 32.7 |
| LUTP3060BK | Phenolic lab surface | 1 | 25 | 60 | 1524 | 30 | 762 | 90 | 40.8 |
| LUTP3072BK | Phenolic lab surface | 1 | 25 | 72 | 1829 | 30 | 762 | 108 | 49.0 |
| LUTP3096BK | Phenolic lab surface | 1 | 25 | 96 | 2438 | 30 | 762 | 144 | 65.3 |
| LUTP30120BK | Phenolic lab surface | 1 | 25 | 120 | 3048 | 30 | 762 | 180 | 81.6 |
| LUTP3624BK | Phenolic lab surface | 1 | 25 | 24 | 610 | 36 | 914 | 43 | 19.5 |
| LUTP3630BK | Phenolic lab surface | 1 | 25 | 30 | 762 | 36 | 914 | 54 | 24.5 |
| LUTP3636BK | Phenolic lab surface | 1 | 25 | 36 | 914 | 36 | 914 | 65 | 29.5 |
| LUTP3648BK | Phenolic lab surface | 1 | 25 | 48 | 1219 | 36 | 914 | 86 | 39.0 |
| LUTP3660BK | Phenolic lab surface | 1 | 25 | 60 | 1524 | 36 | 914 | 108 | 49.0 |
| LUTP3672BK | Phenolic lab surface | 1 | 25 | 72 | 1829 | 36 | 914 | 130 | 59.0 |
| LUTP3696BK | Phenolic lab surface | 1 | 25 | 96 | 2438 | 36 | 914 | 173 | 78.5 |
| LUTP36120BK | Phenolic lab surface | 1 | 25 | 120 | 3048 | 36 | 914 | 216 | 98.0 |

Rev 03/20/12

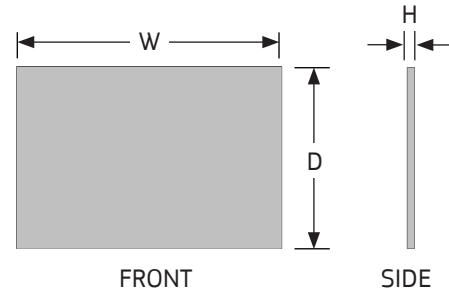
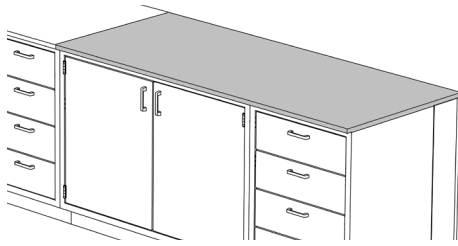

EPOXY LAB SURFACES

- 1" high Epoxy Lab Surfaces have smooth 1/8" radius corners and edges.
- Surfaces are full width and depth and can be mounted to Base Cabinets and/or surface supports.
- Surfaces are not predrilled, but include a drip groove inset from the front edge of the surface (or underside of sink top exposed edges).
- Load capacity 300 lbs. evenly distributed (supported every five feet).
- Surfaces are specially compounded and cured to produce excellent physical, chemical, and heat resistance. Contact factory for detailed testing data.
- Non-glaring matte finish and black in color.

NOTES

- » Mounting hardware not included; recommended attaching method is an approved epoxy adhesive or silicone.
- » See Section 4 for Epoxy Resin Backsplash.
- » Other colors available; Premium pricing. Consult factory.

How to Specify

Step 1. Product Number

LUTE Epoxy Lab Surfaces

Step 2. Depth

24 24" deep 30 30" deep 36 36" deep

Step 3. Width

24 24" wide 30 30" wide 36 36" wide
 48 48" wide 60 60" wide 72 72" wide
 96 96" wide

Step 4. Color Code

BK Black

| PRODUCT NUMBER | DESCRIPTION | HEIGHT | | WIDTH | | DEPTH | | WEIGHT | |
|----------------|-------------------|--------|------|-------|------|-------|------|--------|-------|
| | | IN. | [MM] | IN. | [MM] | IN. | [MM] | LB. | [KG] |
| LUTE2424BK | Epoxy Lab Surface | 1 | 25 | 24 | 610 | 24 | 610 | 44 | 20.0 |
| LUTE2430BK | Epoxy Lab Surface | 1 | 25 | 30 | 762 | 24 | 610 | 55 | 24.9 |
| LUTE2436BK | Epoxy Lab Surface | 1 | 25 | 36 | 914 | 24 | 610 | 66 | 29.9 |
| LUTE2448BK | Epoxy Lab Surface | 1 | 25 | 48 | 1219 | 24 | 610 | 88 | 39.9 |
| LUTE2460BK | Epoxy Lab Surface | 1 | 25 | 60 | 1524 | 24 | 610 | 110 | 49.9 |
| LUTE2472BK | Epoxy Lab Surface | 1 | 25 | 72 | 1829 | 24 | 610 | 132 | 59.9 |
| LUTE2496BK | Epoxy Lab Surface | 1 | 25 | 96 | 2438 | 24 | 610 | 176 | 79.8 |
| LUTE3024BK | Epoxy Lab Surface | 1 | 25 | 24 | 610 | 30 | 762 | 55 | 24.9 |
| LUTE3030BK | Epoxy Lab Surface | 1 | 25 | 30 | 762 | 30 | 762 | 69 | 31.2 |
| LUTE3036BK | Epoxy Lab Surface | 1 | 25 | 36 | 914 | 30 | 762 | 83 | 37.4 |
| LUTE3048BK | Epoxy Lab Surface | 1 | 25 | 48 | 1219 | 30 | 762 | 110 | 49.9 |
| LUTE3060BK | Epoxy Lab Surface | 1 | 25 | 60 | 1524 | 30 | 762 | 138 | 62.4 |
| LUTE3072BK | Epoxy Lab Surface | 1 | 25 | 72 | 1829 | 30 | 762 | 165 | 74.8 |
| LUTE3096BK | Epoxy Lab Surface | 1 | 25 | 96 | 2438 | 30 | 762 | 220 | 99.8 |
| LUTE3624BK | Epoxy Lab Surface | 1 | 25 | 24 | 610 | 36 | 914 | 66 | 29.9 |
| LUTE3630BK | Epoxy Lab Surface | 1 | 25 | 30 | 762 | 36 | 914 | 83 | 37.4 |
| LUTE3636BK | Epoxy Lab Surface | 1 | 25 | 36 | 914 | 36 | 914 | 99 | 44.9 |
| LUTE3648BK | Epoxy Lab Surface | 1 | 25 | 48 | 1219 | 36 | 914 | 132 | 59.9 |
| LUTE3660BK | Epoxy Lab Surface | 1 | 25 | 60 | 1524 | 36 | 914 | 165 | 74.8 |
| LUTE3672BK | Epoxy Lab Surface | 1 | 25 | 72 | 1829 | 36 | 914 | 198 | 89.8 |
| LUTE3696BK | Epoxy Lab Surface | 1 | 25 | 96 | 2438 | 36 | 914 | 264 | 119.7 |

Rev 12/24/20

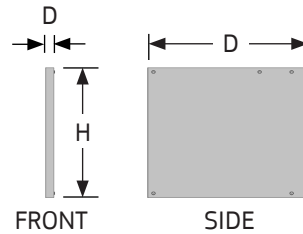
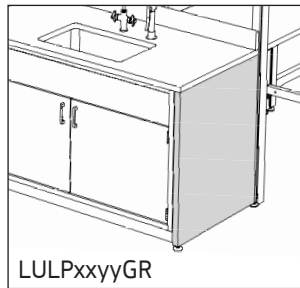
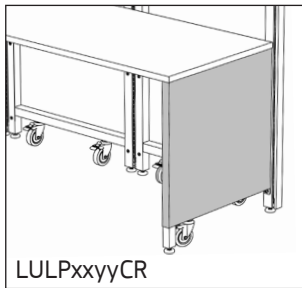

LAB LEG PANELS

- Metal Lab Leg Panels finish the side faces of Lab Legs.
- Lab Leg Panels attach through holes in the Lab Legs with PEM studs and connector nuts.
- Lab Leg Panels for Lab Legs with Casters have clearance at the bottom for caster swivel radius.
- Panels can be used in conjunction with Adjacent Brackets and Reinforcement Bars.

NOTES

- » Lab Leg Panels must be ordered with the same nominal height, depth and glide/caster style as the Lab Leg it will mount on.

How to Specify

Step 1. Product Number

LULP Lab Leg Panel

Step 2. Height

29 29" high 35 35" high

Step 3. Depth

24 24" deep 30 30" deep 36 36" deep

Step 4. Casters or Glide

C Casters G Glide

Step 5. Location

L Left R Right

Step 6. Paint Color Code

BK Black
GL Grey Light Smooth
NW Neutral White

| Product Number | Description | Height | | Width | | Depth | | Weight | |
|----------------|---------------|--------|------|-------|------|--------|------|--------|------|
| | | in. | [mm] | in. | [mm] | in. | [mm] | lb. | [kg] |
| LULP2924CL | Caster, left | 23 3/4 | 603 | 1 1/2 | 38 | 23 3/4 | 603 | 15 | 6.8 |
| LULP2924CR | Caster, right | 23 3/4 | 603 | 1 1/2 | 38 | 23 3/4 | 603 | 15 | 6.8 |
| LULP2924GL | Glide, left | 28 | 711 | 1 1/2 | 38 | 23 3/4 | 603 | 15 | 6.8 |
| LULP2924GR | Glide, right | 28 | 711 | 1 1/2 | 38 | 23 3/4 | 603 | 15 | 6.8 |
| LULP2930CL | Caster, left | 23 3/4 | 603 | 1 1/2 | 38 | 29 3/4 | 756 | 16 | 7.3 |
| LULP2930CR | Caster, right | 23 3/4 | 603 | 1 1/2 | 38 | 29 3/4 | 756 | 16 | 7.3 |
| LULP2930GL | Glide, left | 28 | 711 | 1 1/2 | 38 | 29 3/4 | 756 | 16 | 7.3 |
| LULP2930GR | Glide, right | 28 | 711 | 1 1/2 | 38 | 29 3/4 | 756 | 16 | 7.3 |
| LULP2936CL | Caster, left | 23 3/4 | 603 | 1 1/2 | 38 | 35 3/4 | 908 | 17 | 7.7 |
| LULP2936CR | Caster, right | 23 3/4 | 603 | 1 1/2 | 38 | 35 3/4 | 908 | 17 | 7.7 |
| LULP2936GL | Glide, left | 28 | 711 | 1 1/2 | 38 | 35 3/4 | 908 | 17 | 7.7 |
| LULP2936GR | Glide, right | 28 | 711 | 1 1/2 | 38 | 35 3/4 | 908 | 17 | 7.7 |
| LULP3524CL | Caster, left | 29 3/4 | 756 | 1 1/2 | 38 | 23 3/4 | 603 | 16 | 7.3 |
| LULP3524CR | Caster, right | 29 3/4 | 756 | 1 1/2 | 38 | 23 3/4 | 603 | 16 | 7.3 |
| LULP3524GL | Glide, left | 34 | 864 | 1 1/2 | 38 | 23 3/4 | 603 | 16 | 7.3 |
| LULP3524GR | Glide, right | 34 | 864 | 1 1/2 | 38 | 23 3/4 | 603 | 16 | 7.3 |
| LULP3530CL | Caster, left | 29 3/4 | 756 | 1 1/2 | 38 | 29 3/4 | 756 | 17 | 7.7 |
| LULP3530CR | Caster, right | 29 3/4 | 756 | 1 1/2 | 38 | 29 3/4 | 756 | 17 | 7.7 |
| LULP3530GL | Glide, left | 34 | 864 | 1 1/2 | 38 | 29 3/4 | 756 | 17 | 7.7 |
| LULP3530GR | Glide, right | 34 | 864 | 1 1/2 | 38 | 29 3/4 | 756 | 17 | 7.7 |
| LULP3536CL | Caster, left | 29 3/4 | 756 | 1 1/2 | 38 | 35 3/4 | 908 | 18 | 8.2 |
| LULP3536CR | Caster, right | 29 3/4 | 756 | 1 1/2 | 38 | 35 3/4 | 908 | 18 | 8.2 |
| LULP3536GL | Glide, left | 34 | 864 | 1 1/2 | 38 | 35 3/4 | 908 | 18 | 8.2 |
| LULP3536GR | Glide, right | 34 | 864 | 1 1/2 | 38 | 35 3/4 | 908 | 18 | 8.2 |

Rev 07/07/10

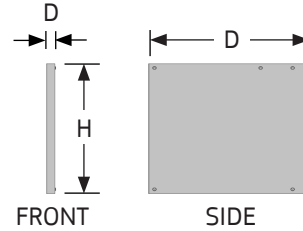
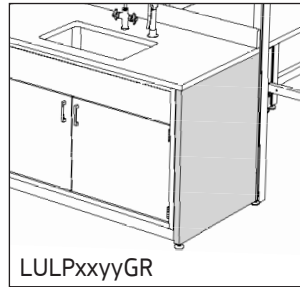
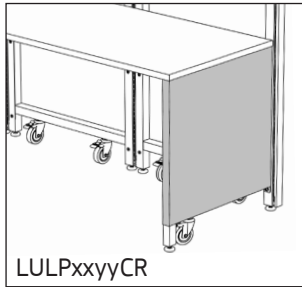

LAB LEG PANELS, ADA

- Metal ADA Lab Leg Panels finish the side faces of ADA Lab Legs.
- ADA Lab Leg Panels attach through holes in the ADA Lab Legs with PEM studs and connector nuts.
- ADA Lab Leg Panels for ADA Lab Legs with Casters have clearance at the bottom for caster swivel radius.
- Panels can be used in conjunction with Adjacent Brackets and Reinforcement Bars.

NOTES

- » ADA Lab Leg Panels must be ordered with the same nominal height, depth and glide/caster style as the ADA Lab Leg it will mount on.

How to Specify

Step 1. Product Number

LULP Lab Leg Panel, ADA

Step 2. Height

33 33" high

Step 3. Depth

24 24" deep 30 30" deep 36 36" deep

Step 4. Casters or Glide

C Casters G Glide

Step 5. Location

L Left R Right

Step 6. Paint Color Code

BK Black
GL Grey Light Smooth
NW Neutral White

| Product Number | Description | Height | | Width | | Depth | | Weight | |
|----------------|---------------|--------|------|-------|------|--------|------|--------|------|
| | | in. | [mm] | in. | [mm] | in. | [mm] | lb. | [kg] |
| LULP3324CL | Caster, left | 27 3/4 | 705 | 1 1/2 | 38 | 23 3/4 | 603 | 16 | 7.3 |
| LULP3324CR | Caster, right | 27 3/4 | 705 | 1 1/2 | 38 | 23 3/4 | 603 | 16 | 7.3 |
| LULP3324GL | Glide, left | 32 | 813 | 1 1/2 | 38 | 23 3/4 | 603 | 16 | 7.3 |
| LULP3324GR | Glide, left | 32 | 813 | 1 1/2 | 38 | 23 3/4 | 603 | 16 | 7.3 |
| LULP3330CL | Caster, left | 27 3/4 | 705 | 1 1/2 | 38 | 29 3/4 | 756 | 17 | 7.7 |
| LULP3330CR | Caster, right | 27 3/4 | 705 | 1 1/2 | 38 | 29 3/4 | 756 | 17 | 7.3 |
| LULP3330GL | Glide, left | 32 | 813 | 1 1/2 | 38 | 29 3/4 | 756 | 17 | 7.3 |
| LULP3330GR | Glide, right | 32 | 813 | 1 1/2 | 38 | 29 3/4 | 756 | 17 | 7.7 |
| LULP3336CL | Caster, left | 27 3/4 | 705 | 1 1/2 | 38 | 35 3/4 | 908 | 18 | 8.2 |
| LULP3336CR | Caster, right | 27 3/4 | 705 | 1 1/2 | 38 | 35 3/4 | 908 | 18 | 8.2 |
| LULP3336GL | Glide, left | 32 | 813 | 1 1/2 | 38 | 35 3/4 | 908 | 18 | 8.2 |
| LULP3336GR | Glide, right | 32 | 813 | 1 1/2 | 38 | 35 3/4 | 908 | 18 | 8.2 |

Rev 08/20/20

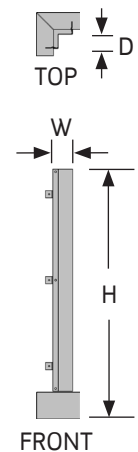
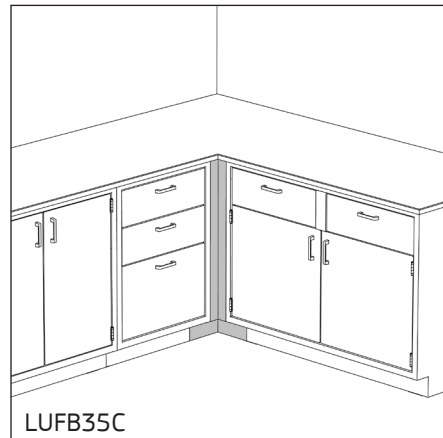
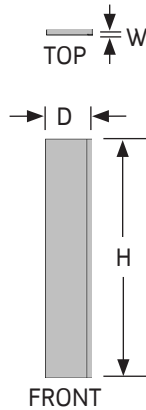
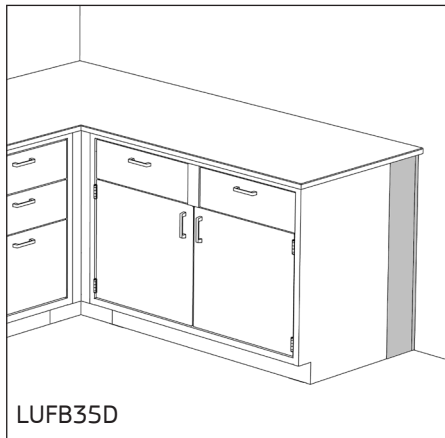

LAB CABINET FILLERS

Rear Base Cabinet Fillers

- Rear Fillers are used in the space between the rear of the cabinet and the wall.
- Fillers provide a clean finished look when surfaces are deeper than the base cabinets and conceal any utilities that are routed behind cabinets.
- Includes a filler panel and a slip joint, which mounts to the wall.

Inside Corner Base Cabinet Fillers

- Corner Fillers are used where two base cabinets meet at a ninety degree angle.
- Includes an angled filler panel, which provides either 1", 2" or 4" clearance between cabinet fronts, mounting clips to attach the filler to the cabinets, and a toekick to conceal cabinet spacing.

NOTES

- » Hardware is not provided to mount filler slip joint to wall.

How to Specify

Step 1. Product Number

LUFB Lab Cabinet Filler

Step 2. Height

35 35" high

Step 3. Location

C Inside Corner D Rear

Step 4. Width (Inside Corner Only)

01 1" wide 02 2" wide 04 4" wide

Step 5. Depth (Deep Surface Only)

24 24" deep 30 30" deep 36 36" deep

Step 6. Paint Color Code

BK Black
 GL Grey Light Smooth
 NW Neutral White

| Product Number | Description | Height | | Width | | Depth | | Weight | |
|----------------|------------------------|--------|------|-------|------|-------|------|--------|------|
| | | in. | [mm] | in. | [mm] | in. | [mm] | lb. | [kg] |
| LUFB35C01 | Inside corner | 35 | 889 | 1 | 25 | 1 | 25 | 7 | 3.2 |
| LUFB35C02 | Inside corner | 35 | 889 | 2 | 51 | 2 | 51 | 8 | 3.6 |
| LUFB35C04 | Inside corner | 35 | 889 | 4 | 102 | 4 | 102 | 9 | 4.1 |
| LUFB35D24 | Rear, 24" deep surface | 35 | 889 | 1 | 25 | 1 | 25 | 3 | 1.4 |
| LUFB35D30 | Rear, 30" deep surface | 35 | 889 | 1 | 25 | 7 | 178 | 4 | 1.8 |
| LUFB35D36 | Rear, 36" deep surface | 35 | 889 | 1 | 25 | 13 | 330 | 7 | 3.2 |

Rev 10/20/10

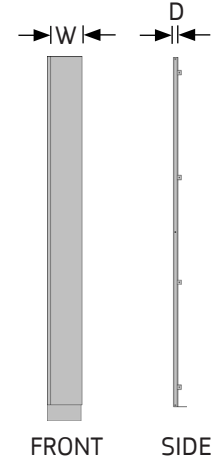
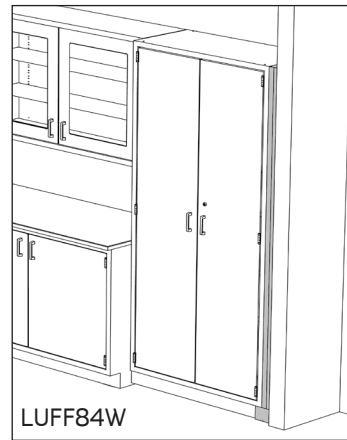
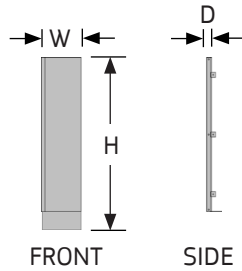
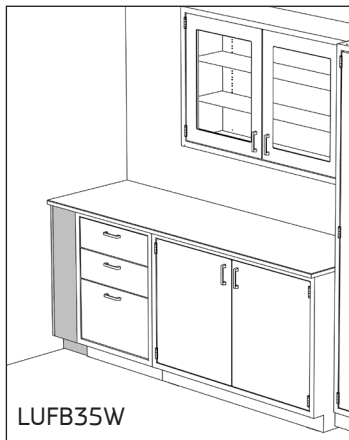

LAB CABINET FILLERS, CONT'D

Front Cabinet Fillers

- Front Fillers are used when there is excess space between the side of the Base Cabinet or Floor Case and a wall.
- Filler kit includes a filler panel, mounting clips to attach the filler to the cabinet, a slip joint, which mounts to the wall and a toekick to conceal cabinet spacing.
- Filler panel and toekick can be cut to width in the field to accommodate custom spacing.

NOTES

- » Hardware is not provided to mount filler slip joint to wall.

How to Specify

Step 1. Product Number

LUFB Front Cabinet Filler

Step 2. Height

35 35" high 84 84" high

Step 3. Location

W Wall

Step 4. Width

2 2" wide (floor case only)

8 8" wide

14 14" wide (base only)

Step 5. Paint Color Code

BK Black

GL Grey Light Smooth

NW Neutral White

| Product Number | Description | Height | | Width | | Depth | | Weight | |
|----------------|---------------|--------|------|-------|------|-------|------|--------|------|
| | | in. | [mm] | in. | [mm] | in. | [mm] | lb. | [kg] |
| LUFB35W08 | Base cabinets | 35 | 889 | 8 | 203 | 1 | 25 | 10 | 4.5 |
| LUFB35W14 | Base cabinets | 35 | 889 | 14 | 356 | 1 | 25 | 12 | 5.4 |
| LUFF84W02 | Floor case | 84 | 2134 | 2 | 51 | 1 | 25 | 22 | 10.0 |
| LUFF84W08 | Floor case | 84 | 2134 | 8 | 203 | 1 | 25 | 25 | 11.3 |

Rev 02/20/10

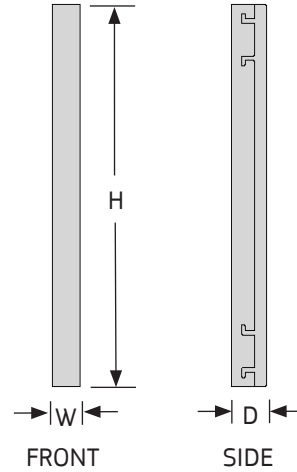
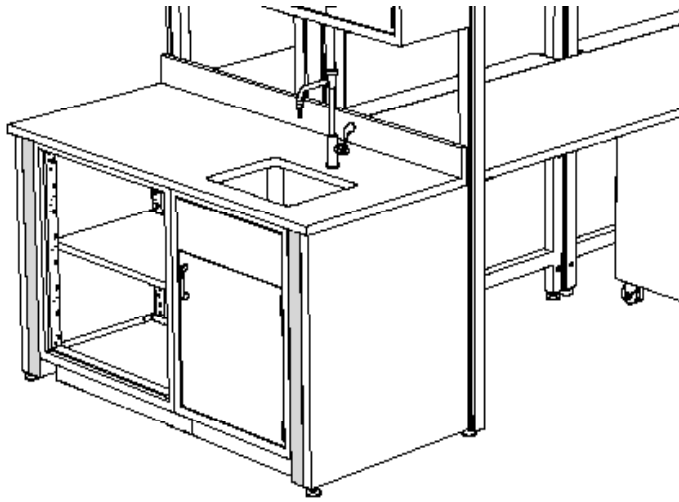

LAB LEG FILLERS

- Lab Leg Fillers are used to fill the gap between Lab Legs and adjacent Base Cabinets in an end of run configuration using a Three-way Connector.
- Fillers mount directly to Lab Legs without the need to add holes or hardware to either the leg or adjacent cabinet.

NOTES

- » Hardware to attach Lab Leg Filler is included with the Lab Leg Panel; see page 10.31. If Lab Leg Panels will not be used in conjunction with Lab Leg Fillers, please consult factory for Lab Leg Filler hardware ordering information.
- » Order two half gap style fillers if the difference between the total cabinet width and frame run is 9½" or greater. Order a single full gap filler if the cabinet/frame run difference is 5½".
- » Two half gap style fillers are shown in the above image.

How to Specify

Step 1. Product Number

LULF Lab Leg Filler

Step 2. Height

35 35" high

Step 3. Width

E01 1" wide E02 2½" wide E03 3½" wide

Step 4. Paint Color Code

BK Black
 GL Grey Light Smooth
 NW Neutral White

| Product Number | Description | Height | | Width | | Depth | | Weight | |
|----------------|-------------|--------|------|-------|------|-------|------|--------|------|
| | | in. | [mm] | in. | [mm] | in. | [mm] | lb. | [kg] |
| LULF35E01 | Full gap | 35 | 889 | 1 | 25 | 3 | 76 | 3 | 1.4 |
| LULF35E02 | Half gap | 35 | 889 | 2 ½ | 64 | 3 | 76 | 3 ½ | 1.6 |
| LULF35E03 | Half gap | 35 | 889 | 3 ½ | 89 | 3 | 76 | 4 | 1.8 |

Rev 10/20/10

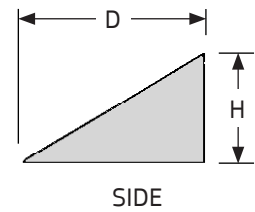
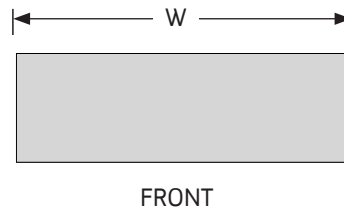
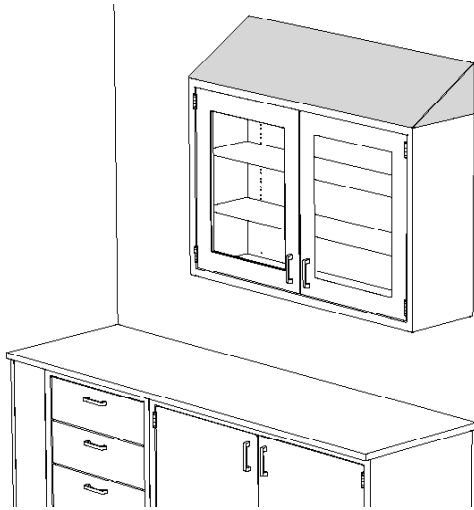

SLOPED TOP COVERS

- Covers are made of welded 18 and 20 gauge steel construction with a chemical resistant epoxy powder coat paint finish.
- Slanted top covers inhibit the collection and clutter of items placed on top of wall and floor cases.
- Mounting hardware included.
- Built to SEFA standards.
- Use 13" deep on wall cases; 16" deep on floor cases.

How to Specify

Step 1. Product Number

LUCT Sloped Top Cover

Step 2. Depth

13 13" deep 16 16" deep

Step 3. Width

24 24" wide 30 30" wide 36 36" wide
48 48" wide

Step 4. Paint Color Code

BK Black
GL Grey Light Smooth
NW Neutral White

| Product Number | Description | Height | | Width | | Depth | | Weight | |
|----------------|------------------|--------|------|-------|------|-------|------|--------|------|
| | | in. | [mm] | in. | [mm] | in. | [mm] | lb. | [kg] |
| LUCT1324 | Sloped top cover | 7 ¾ | 197 | 24 | 610 | 13 | 330 | 4 | 1.8 |
| LUCT1330 | Sloped top cover | 7 ¾ | 197 | 30 | 762 | 13 | 330 | 4 | 1.8 |
| LUCT1336 | Sloped top cover | 7 ¾ | 197 | 36 | 914 | 13 | 330 | 5 | 2.3 |
| LUCT1348 | Sloped top cover | 7 ¾ | 197 | 48 | 1219 | 13 | 330 | 6 | 2.7 |
| LUCT1636 | Sloped top cover | 7 ¾ | 197 | 36 | 914 | 16 | 406 | 8 | 3.6 |
| LUCT1648 | Sloped top cover | 7 ¾ | 197 | 48 | 1219 | 16 | 406 | 9 | 4.1 |

Rev 02/12/18

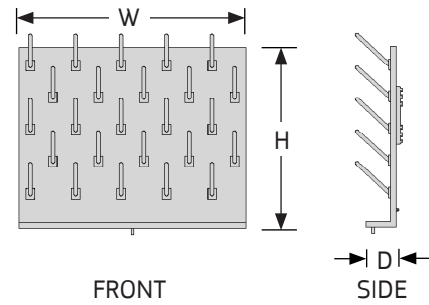
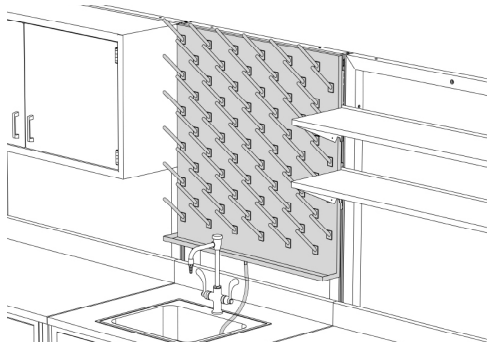

DRAIN BOARD, FRAME-MOUNT

- Frame-mount drain board is constructed of 20 gauge, type 304 stainless steel, polished to a #4 finish.
- Drain boards allow you to quickly dry important, and often fragile, equipment in a sanitary manner.
- Integral stainless steel drip trough included.
- Includes a 3' section of clear plastic drain tubing.

NOTES

- » Standard 6" white pegs are included.

How to Specify

Step 1. Product Number

DBF Drain Board, Frame-Mount

Step 2. Height

18 18" high 24 24" high 30 30" high
36 36" high

Step 3. Width

24 24" wide 30 30" wide 36 36" wide

Step 4. Trough Size

2 2" deep 4 4" deep

| Product Number | Description | Height | | Width | | Depth | | Weight | |
|----------------|-------------------------|--------|------|-------|------|-------|------|--------|------|
| | | in. | [mm] | in. | [mm] | in. | [mm] | lb. | [kg] |
| DBF18242 | 2" drip trough, 16 pegs | 18 | 457 | 24 | 610 | 2 | 51 | 22 | 10.0 |
| DBF18244 | 4" drip trough, 16 pegs | 18 | 457 | 24 | 610 | 4 | 102 | 22 | 10.0 |
| DBF24242 | 2" drip trough, 20 pegs | 24 | 610 | 24 | 610 | 2 | 51 | 26 | 11.8 |
| DBF24244 | 4" drip trough, 20 pegs | 24 | 610 | 24 | 610 | 4 | 102 | 26 | 11.8 |
| DBF24302 | 2" drip trough, 25 pegs | 24 | 610 | 30 | 762 | 2 | 51 | 31 | 14.1 |
| DBF24304 | 4" drip trough, 25 pegs | 24 | 610 | 30 | 762 | 4 | 102 | 31 | 14.1 |
| DBF24362 | 2" drip trough, 30 pegs | 24 | 610 | 36 | 914 | 2 | 51 | 33 | 15.0 |
| DBF24364 | 4" drip trough, 30 pegs | 24 | 610 | 36 | 914 | 4 | 102 | 33 | 15.0 |
| DBF30242 | 2" drip trough, 32 pegs | 30 | 762 | 24 | 610 | 2 | 51 | 31 | 14.1 |
| DBF30244 | 4" drip trough, 32 pegs | 30 | 762 | 24 | 610 | 4 | 102 | 31 | 14.1 |
| DBF30302 | 2" drip trough, 50 pegs | 30 | 762 | 30 | 762 | 2 | 51 | 38 | 17.2 |
| DBF30304 | 4" drip trough, 50 pegs | 30 | 762 | 30 | 762 | 4 | 102 | 38 | 17.2 |
| DBF30362 | 2" drip trough, 60 pegs | 30 | 762 | 36 | 914 | 2 | 51 | 39 | 17.7 |
| DBF30364 | 4" drip trough, 60 pegs | 30 | 762 | 36 | 914 | 4 | 102 | 39 | 17.7 |
| DBF36242 | 2" drip trough, 40 pegs | 36 | 914 | 24 | 610 | 2 | 51 | 34 | 15.4 |
| DBF36244 | 4" drip trough, 40 pegs | 36 | 914 | 24 | 610 | 4 | 102 | 34 | 15.4 |
| DBF36302 | 2" drip trough, 40 pegs | 36 | 914 | 30 | 762 | 2 | 51 | 39 | 17.7 |
| DBF36304 | 4" drip trough, 40 pegs | 36 | 914 | 30 | 762 | 4 | 102 | 39 | 17.7 |
| DBF36362 | 2" drip trough, 66 pegs | 36 | 914 | 36 | 914 | 2 | 51 | 42 | 19.1 |
| DBF36364 | 4" drip trough, 66 pegs | 36 | 914 | 36 | 914 | 4 | 102 | 42 | 19.1 |

Rev 02/12/18

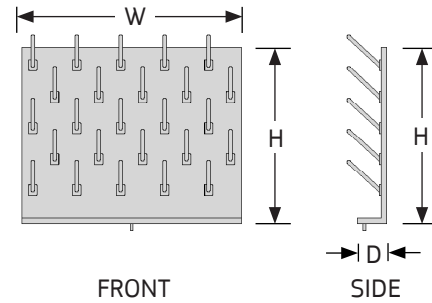
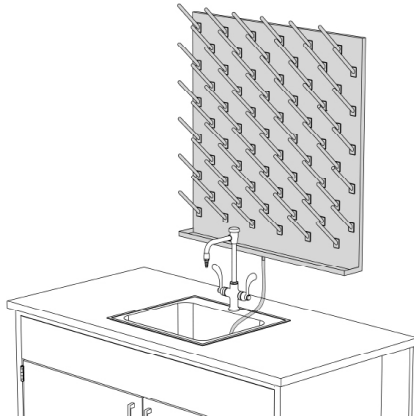

DRAIN BOARD, WALL-MOUNT

- Wall mount drain board is constructed of 20 gauge, type 304 stainless steel, polished to a #4 finish.
- Drain boards allow you to quickly dry important, and often fragile, equipment in a sanitary manner.
- Integral stainless steel drip trough included.
- Includes a 3' section of clear plastic drain tubing.

NOTES

» Standard 6" white pegs are included.

How to Specify

Step 1. Product Number

DBW Drain Board, Wall-Mount

Step 2. Height

18 18" high 24 24" high 30 30" high
36 36" high

Step 3. Width

24 24" wide 30 30" wide 36 36" wide

Step 4. Trough Size

2 2" deep 4 4" deep

| Product Number | Description | Height | | Width | | Depth | | Weight | |
|----------------|-------------------------|--------|------|-------|------|-------|------|--------|------|
| | | in. | [mm] | in. | [mm] | in. | [mm] | lb. | [kg] |
| DBW18242 | 2" drip trough, 16 pegs | 18 | 457 | 24 | 610 | 2 | 51 | 13 | 5.9 |
| DBW18244 | 4" drip trough, 16 pegs | 18 | 457 | 24 | 610 | 4 | 102 | 13 | 5.9 |
| DBW24242 | 2" drip trough, 20 pegs | 24 | 610 | 24 | 610 | 2 | 51 | 16 | 7.3 |
| DBW24244 | 4" drip trough, 20 pegs | 24 | 610 | 24 | 610 | 4 | 102 | 16 | 7.3 |
| DBW24302 | 2" drip trough, 25 pegs | 24 | 610 | 30 | 762 | 2 | 51 | 20 | 9.1 |
| DBW24304 | 4" drip trough, 25 pegs | 24 | 610 | 30 | 762 | 4 | 102 | 20 | 9.1 |
| DBW24362 | 2" drip trough, 30 pegs | 24 | 610 | 36 | 914 | 2 | 51 | 21 | 9.5 |
| DBW24364 | 4" drip trough, 30 pegs | 24 | 610 | 36 | 914 | 4 | 102 | 21 | 9.5 |
| DBW30242 | 2" drip trough, 32 pegs | 30 | 762 | 24 | 610 | 2 | 51 | 19 | 8.6 |
| DBW30244 | 4" drip trough, 32 pegs | 30 | 762 | 24 | 610 | 4 | 102 | 19 | 8.6 |
| DBW30302 | 2" drip trough, 50 pegs | 30 | 762 | 30 | 762 | 2 | 51 | 24 | 10.9 |
| DBW30304 | 4" drip trough, 50 pegs | 30 | 762 | 30 | 762 | 4 | 102 | 24 | 10.9 |
| DBW30362 | 2" drip trough, 60 pegs | 30 | 762 | 36 | 914 | 2 | 51 | 23 | 10.4 |
| DBW30364 | 4" drip trough, 60 pegs | 30 | 762 | 36 | 914 | 4 | 102 | 23 | 10.4 |
| DBW36242 | 2" drip trough, 40 pegs | 36 | 914 | 24 | 610 | 2 | 51 | 21 | 9.5 |
| DBW36244 | 4" drip trough, 40 pegs | 36 | 914 | 24 | 610 | 4 | 102 | 21 | 9.5 |
| DBW36302 | 2" drip trough, 40 pegs | 36 | 914 | 30 | 762 | 2 | 51 | 23 | 10.4 |
| DBW36304 | 4" drip trough, 40 pegs | 36 | 914 | 30 | 762 | 4 | 102 | 23 | 10.4 |
| DBW36362 | 2" drip trough, 66 pegs | 36 | 914 | 36 | 914 | 2 | 51 | 25 | 11.3 |
| DBW36364 | 4" drip trough, 66 pegs | 36 | 914 | 36 | 914 | 4 | 102 | 25 | 11.3 |

Rev 02/12/18

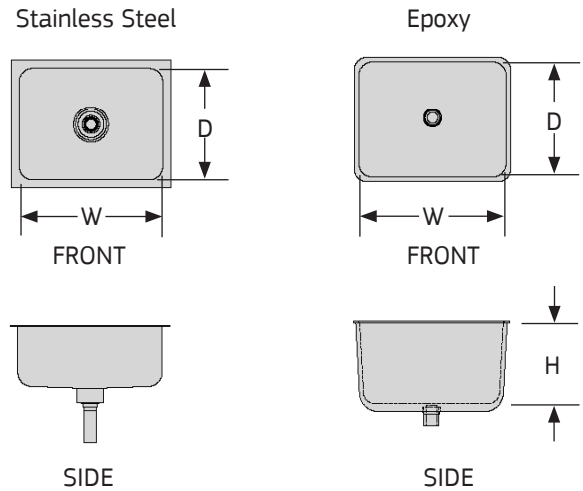
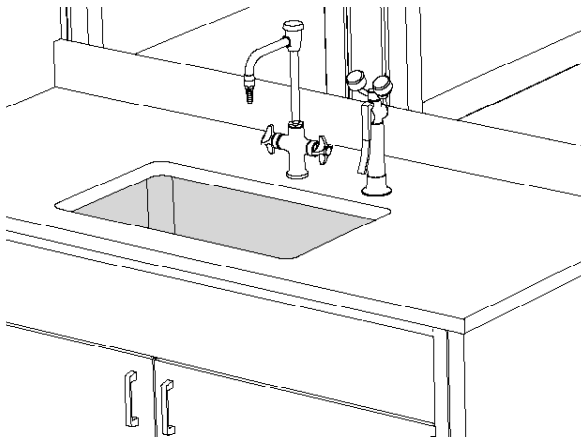

SINK, UNDERMOUNT

- Undermount sinks are installed under a cutout in the surface. Sink supports are required (see below).
- Stainless steel sinks are constructed of 18 gauge, type 304 stainless steel, polished to a #4 finish.
- Stainless steel sinks include stainless steel drain with crumb cup strainer and tailpiece.
- Epoxy sinks are resistant to many acids, solvents and other inert chemicals.
- Epoxy sinks include a sink outlet with strainer plate and integral tailpiece.

NOTES

- » Sinks can be paired with Symbiote phenolic and stainless steel worksurfaces. (See Section 4).
- » Stainless Steel sinks are certified to ASME A112.19.3.

How to Specify

Step 1. Product Number

LUWS Sink
 LUWP Undermount Support

Step 2. Sink Type

EOU Epoxy SOU Stainless

Step 3. Depth (Sink only)

14 14" deep 15 15" deep 16 16" deep
 18 18" deep (stainless only)

Step 4. Width (Sink only)

18 18" wide 20 20" wide 24 24" wide
 25 25" wide

Step 5. Width (Support Only)

24 24" wide 30 30" wide 36 36" wide
 48 48" wide 52 52" wide

| Product Number | Description | Height | | Width | | Depth | | Weight | |
|----------------|---|--------|------|-------|------|-------|------|--------|------|
| | | in. | [mm] | in. | [mm] | in. | [mm] | lb. | [kg] |
| LUWSEOU1418F | Epoxy, center drain | 10 ½ | 267 | 18 | 457 | 14 | 356 | 38 | 17.2 |
| LUWSEOU1525E | Epoxy, corner drain | 10 | 254 | 25 | 635 | 15 | 381 | 60 | 27.2 |
| LUWSSOU1620C | Stainless steel, center drain | 7 ½ | 191 | 18 | 457 | 14 | 356 | 11 | 5.0 |
| LUWSSOU1824C | Stainless steel, center drain | 7 ½ | 191 | 22 | 559 | 16 | 406 | 14 | 6.4 |
| LUWP24 | Undermount support for 24" wide sink base | 15 ½ | 394 | 23 | 584 | | | 9 | 4.1 |
| LUWP30 | Undermount support for 30" wide sink base | 15 ½ | 394 | 29 | 737 | | | 10 | 4.5 |
| LUWP36 | Undermount support for 36" wide sink base | 15 ½ | 394 | 35 | 889 | | | 12 | 5.4 |
| LUWP42 | Undermount support for 42" wide sink base | 15 ½ | 394 | 41 | 1041 | | | 12 | 5.4 |
| LUWP48 | Undermount support for 48" wide sink base | 15 ½ | 394 | 47 | 1194 | | | 13 | 5.9 |
| LUWP52 | Undermount support for 52" wide sink base | 15 ½ | 394 | 51 | 1295 | | | 14 | 6.4 |
| LUWP58 | Undermount support for 58" wide sink base | 15 ½ | 394 | 57 | 1448 | | | 15 | 6.8 |

Rev 02/26/18

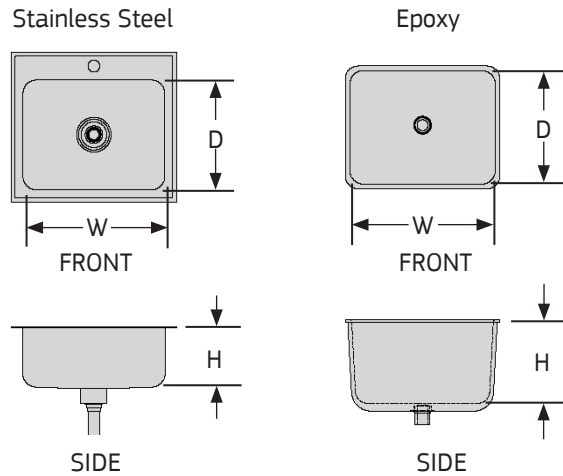
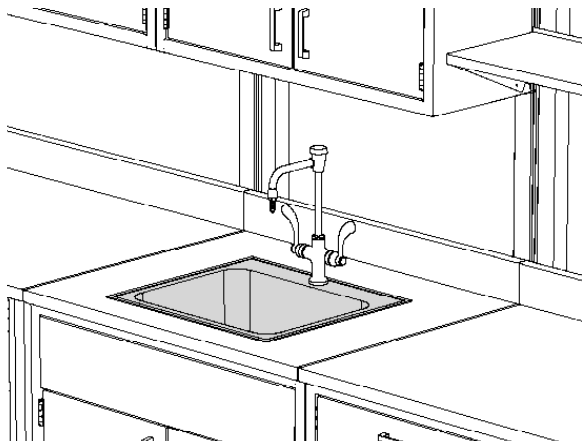

SINK, DROP-IN

- Drop-in sinks are top mounted. This type of installation seals the sink cutout and eliminates worksurface overhang.
- Stainless steel sinks are constructed of 18 gauge, type 304 stainless steel, polished to a #4 finish.
- Stainless steel sinks include stainless steel drain with crumb cup strainer and tailpiece.
- Epoxy sinks are resistant to many acids, solvents and other inert chemicals.
- Epoxy sinks include a sink outlet with strainer plate and integral tailpiece.

NOTES

- » Sinks can be paired with Symbiote laminate, phenolic and stainless steel worksurfaces. (See Section 4).
- » Stainless Steel sinks are certified to ASME A112.19.3.

How to Specify

Step 1. Product Number

LUWS Sink, Drop-In

Step 2. Sink Type

E Epoxy S Stainless

Step 3. Fixture Holes

OD No fixture holes 1D One fixture hole

Step 4. Depth

14 14" deep 15 15" deep 19 19" deep
22 22" deep

Step 5. Width

18 18" wide 21 21" wide 25 25" wide

Step 6. Sink Height

C 7½" high E 10" high F 10½" high

| Product Number | Description | Height | | Width | | Depth | | Weight | |
|----------------|---|--------|------|-------|------|-------|------|--------|------|
| | | in. | [mm] | in. | [mm] | in. | [mm] | lb. | [kg] |
| LUWSEOD1418F | Epoxy, center drain, no fixture holes | 10 ½ | 267 | 18 | 457 | 14 | 356 | 30 | 13.6 |
| LUWSEOD1525E | Epoxy, corner drain, no fixture holes | 10 | 254 | 25 | 635 | 15 | 381 | 72 | 32.7 |
| LUWSS1D1921C | Stainless steel, center drain, 1 fixture hole | 7 ½ | 191 | 21 | 457 | 19 | 356 | 13 | 5.9 |
| LUWSS1D2225C | Stainless steel, center drain, 1 fixture hole | 10 ½ | 267 | 25 | 559 | 22 | 406 | 21 | 9.5 |

Rev 02/26/18

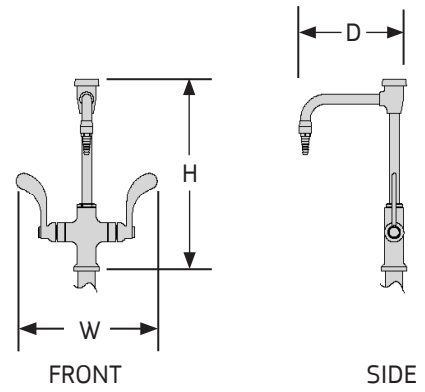
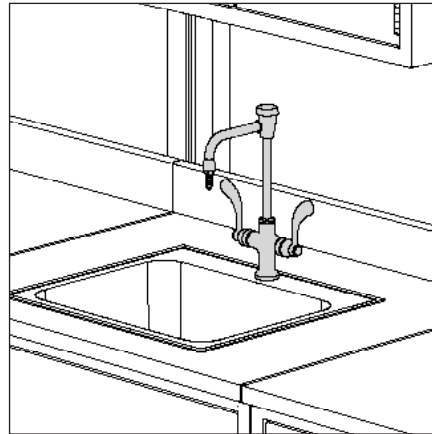
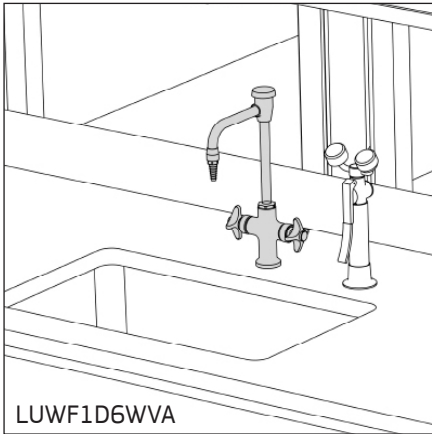

SINK FAUCETS, UNDERMOUNT AND DROP-IN

Four-Arm Handle Faucet

- Deck mounted mixing faucet with vacuum breaker for hot and cold water. 6" swing gooseneck.
- Forged brass body and four-arm handles with color-coded index discs.
- 3/8" NPS female outlet with removable anti-splash serration hose end.

Blade Handle Faucet

- Deck mounted mixing faucet with vacuum breaker and blade handle(s) for hot and cold water. 6" swing gooseneck.
- Forged brass body and blade handle(s) with color-coded index disc(s).
- 3/8" NPS female outlet with removable anti-splash serration hose end.

NOTES

- » Fixture is certified by CSA International to comply with ASME A112.18.1M and CSA B125.1.
- » Fixture is fully assembled and factory tested prior to shipment.

How to Specify

Step 1. Product Number

LUWF Sink Faucet

Step 2. Type

- 1D6 Mixing, double handles
- 1R6 Single, right hand handle

Step 3. Handle

- WVA 4-Arm handle
- WVB Blade handles

| Product Number | Description | Height | | Width | | Depth | | Weight | |
|----------------|-----------------------|--------|------|-------|------|-------|------|--------|------|
| | | in. | [mm] | in. | [mm] | in. | [mm] | lb. | [kg] |
| LUWF1D6WVA | Mixing, 4-arm handles | 13 | 330 | 6 1/2 | 165 | 7 5/8 | 194 | 5 | 2.3 |
| LUWF1D6WVB | Mixing, blade handles | 13 | 330 | 9 5/8 | 244 | 7 5/8 | 194 | 5 | 2.3 |
| LUWF1R6WVB | Single, blade handle | 13 | 330 | 5 1/3 | 135 | 7 3/8 | 187 | 4 | 1.8 |

Rev 02/26/18

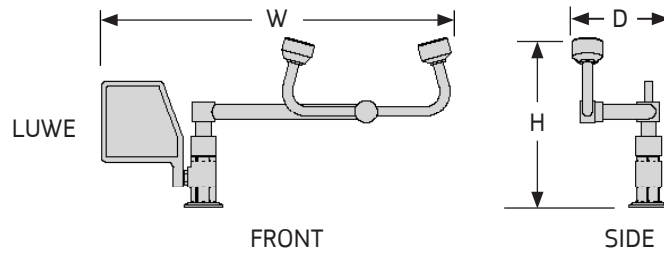
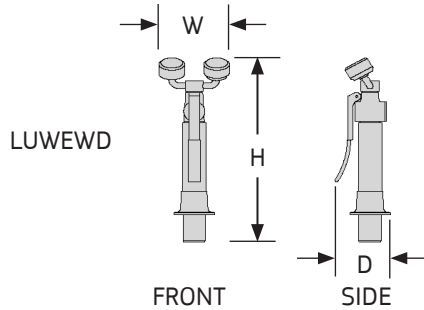
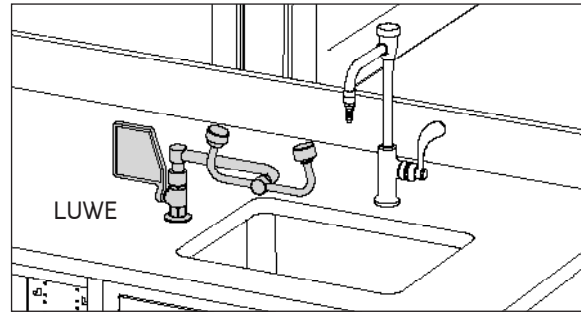
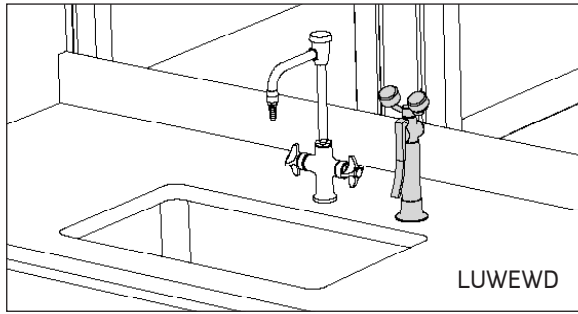

EYEWASH STATIONS

Eyewash/Drench Hose Unit, Deck Mounted

- Dual purpose, eyewash/drench hose assembly can be left as a fixed eye wash or removed to use as a drench hose.
- Two outlet heads with "flip-top" dust covers are mounted on chrome plated brass supply arms.
- Locking clip engages when handle is depressed. Valve stays open until locking clip is released.
- Includes an 8' reinforced PVC hose. 275 PSI hose rating. Unit is completely assembled and water tested prior to shipment.

Swing Activated Eyewash Unit, Deck Mounted

- Eyewash unit is deck mounted on counter next to sink. Spray heads swivel 90° from storage to operational position.
- Includes twin spray heads with protective covers and a large push handle. Water flow is activated by flag handle; specify LH or RH.
- Unit is completely assembled and water tested prior to shipment.

NOTES

- » Eyewash stations can be easily mounted next to the sink for maximum accessibility.
- » Eyewashes meet the provisions of ANSI Z358.1-2014.

How to Specify

Step 1. Product Number

LUWEW Eyewash Station

Step 2. Mount Type

- D Drench
- L Left hand, swing style
- R Right hand, swing style

| Product Number | Description | Height | | Width | | Depth | | Weight | |
|----------------|------------------------|--------|------|--------|------|-------|------|--------|------|
| | | in. | [mm] | in. | [mm] | in. | [mm] | lb. | [kg] |
| LUWEWD | Drench unit | 10 1/8 | 257 | 4 1/8 | 105 | 3 1/4 | 83 | 5 | 2.3 |
| LUWEWL | Left-hand swing style | 8 3/8 | 213 | 17 1/8 | 435 | 4 5/8 | 117 | 4 | 1.8 |
| LUWEWR | Right-hand swing style | 8 3/8 | 213 | 17 1/8 | 435 | 4 5/8 | 117 | 4 | 1.8 |

Rev 02/26/18

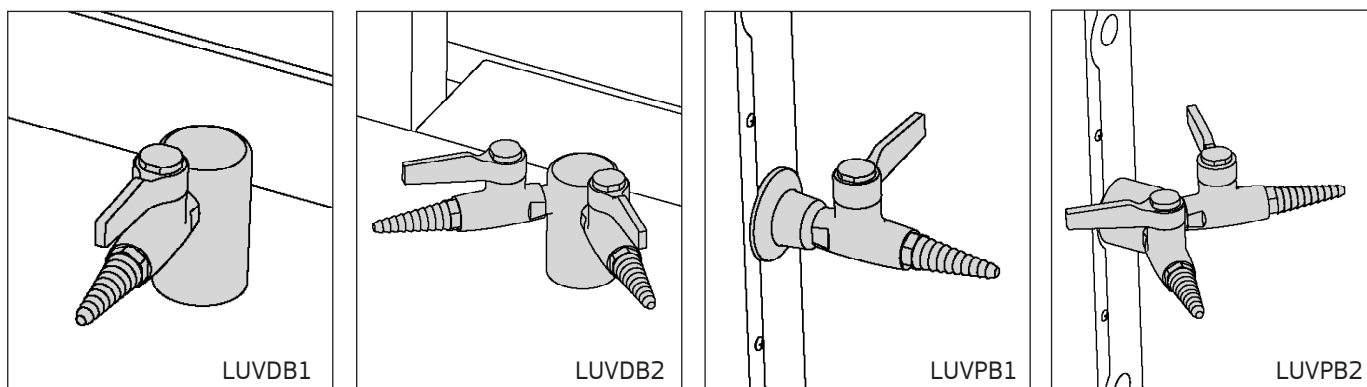

BALL VALVES

Ball Valves

- Single or double ball valves offer on/off control of lab gasses at pressures up to 75 psi.
- Fixtures have a forged brass valve body and lever handle with chrome-plated brass ball and molded PTFE seals.
- Valves have a 3/8" NPT male inlet with 3/8" IPS mounting shank, washer and locknut.
- 3/8" NPT female outlet includes removable ten serration hose end and color-coded index disc on the quarter turn lever handle.
- Finish is polished chrome plating.

Hoses

- Hose assemblies have a 3/8" NPT male connector on each end, include a 3/8" NPT female elbow connector and are rated for 300 psi maximum working pressure.
- PVC style hoses have a 5/8" O.D. reinforced PVC hose with nylon braid and 3/8" I.D. PVC inner core.
- Stainless steel hoses have a stainless steel overbraid with PTFE inner core.
- Hose length specified in inches (096 and 120 are standard lengths).

NOTES

- » Fixture certified by CSA International to comply with ASME A112.18.1M and CSA B125.1.
- » Fixture is fully assembled and factory tested prior to shipment.

How to Specify

Step 1. Product Number

- LUVDB Ball Valve, deck-mount
- LUVPB Ball Valve, panel-mount
- LUVHP PVC Hose
- LUVHS Stainless Steel Hose

Step 2a. Valve Type (Valves)

- 1 Single 2 Double

Step 2b. Hose Length (Hoses)

- 096 96" length 120 120" length

Step 3a. Index Disc Cap (Valves)

- AIR Air GAS Gas
- NIT Nitrogen VAC Vacuum

Step 3b. Hose Color (Hoses)

- BLU Blue BRN Brown
- ORG Orange YEL Yellow

| Product Number | Description | Length | | Width | | Depth | | Weight | |
|----------------|--------------------------------|--------|------|-------|------|-------|------|--------|------|
| | | in. | [mm] | in. | [mm] | in. | [mm] | lb. | [kg] |
| LUVDB1 | Deck-mount, single valve | | | | | | | 1 | 0.5 |
| LUVDB2 | Deck-mount, double valve | | | | | | | 2 | 0.9 |
| LUVPB1 | Panel-mount, single valve | | | | | | | 1 | 0.5 |
| LUVPB2 | Panel-mount, double valve | | | | | | | 1 | 0.5 |
| LUVHP096 | PVC hose | 96 | 2438 | | | | | 2 | 0.9 |
| LUVHP120 | PVC hose | 120 | 3048 | | | | | 2 | 0.9 |
| LUVHS096 | Stainless steel overbraid hose | 96 | 2438 | | | | | 2 | 0.9 |
| LUVHS120 | Stainless steel overbraid hose | 120 | 3048 | | | | | 2 | 0.9 |

Rev 06/03/19

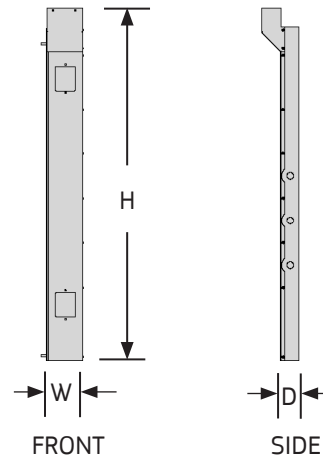
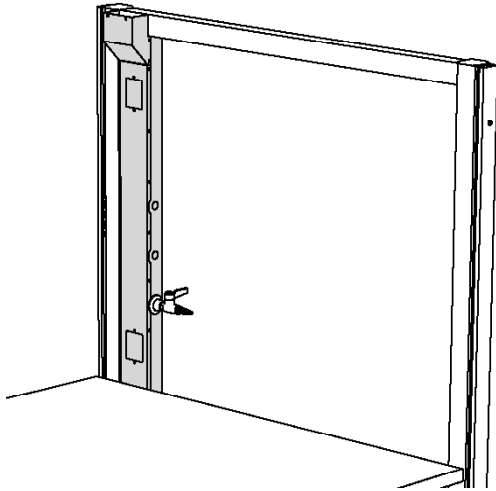

VERTICAL UTILITY CHASE, ERGOSTAT RISER FRAME

- Vertical utility chase offers utility flexibility in the lab without compromising the height adjustability.
- A total of three utility control/outlet knockouts are placed within easy reach on the vertical chase.
- Standard wall faceplate knockouts are provided at the top and bottom of the front of the Vertical Utility chase.
- Top access router included with each vertical utility chase.
- Vertical utility chase housing divider allows for separation of utilities within the chase.

NOTES

- » Housing dividers sold separately.
- » Data jack ports and faceplates not included.
- » 43" Vertical Utility Chase Housings can only be mounted on ErgoStat Riser Frames.

How to Specify

Step 1. Product Number

- VUCH Vertical Utility Chase Housing
- VUCHD Vertical Utility Chase Divider

Step 2. Height

43 43" high

Step 2. Mount Location (Chase Housing only)

- L Left-Hand
- R Right-Hand

| Product Number | Description | Height | | Width | | Depth | | Weight | |
|----------------|---------------------|--------|------|-------|------|-------|------|--------|------|
| | | in. | [mm] | in. | [mm] | in. | [mm] | lb. | [kg] |
| VUCH43L | Housing, left-hand | 39 ½ | 1003 | 4 | 102 | 2 ⅞ | 54 | 7 | 3.2 |
| VUCH43R | Housing, right-hand | 39 ½ | 1003 | 4 | 102 | 2 ⅞ | 54 | 7 | 3.2 |
| VUCHD43 | Housing divider | 39 ½ | 1003 | 1 ⅞ | 29 | 2 | 51 | 2 | 0.9 |

Rev 05/31/18

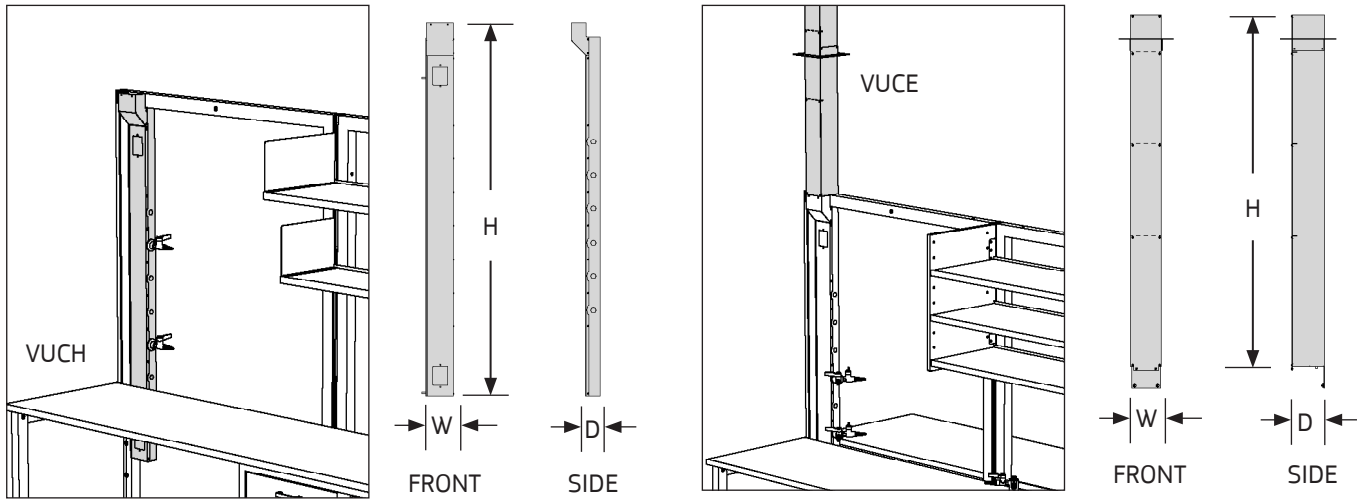

VERTICAL UTILITY CHASE, ULTRAFRAME

- Vertical utility chase offers utility flexibility in the lab without compromising the height adjustability of work surfaces on benches.
- A total of six utility control/outlet knockouts are placed within easy reach on the vertical chase.
- Standard wall faceplate knockouts are provided at the top and bottom of the front and back sides of the Vertical Utility chase.
- Top access router included with each vertical utility chase.
- Extender conceals utilities routed from the ceiling to the top of the UltraFrame and can be trimmed on site as needed for ceilings up to 10'6" H.
- Extender and housing dividers allow for separation of utilities within the chase and can be trimmed in the field as needed.

NOTES

- » Housing dividers and extenders sold separately.
- » Data jack ports and faceplates not included.
- » Color matched ceiling trim plate included with extender.
- » 80" Vertical Utility Chase Housings and Extenders only mount on 80" high UltraFrames.

How to Specify

Step 1. Product Number

- VUCH80 Utility Chase Housing
- VUCHD80 Housing Divider
- VUCE46 Extender
- VUCED46 Extender Divider

Step 2. Handed (Housing only)

- L Left-Hand R Right-Hand

| Product Number | Description | Height | | Width | | Depth | | Weight | |
|----------------|---------------------|--------|------|-------|------|-------|------|--------|------|
| | | in. | [mm] | in. | [mm] | in. | [mm] | lb. | [kg] |
| VUCH80L | Housing, left-hand | 55 5/8 | 1413 | 4 | 102 | 2 1/8 | 54 | 10 | 4.5 |
| VUCH80R | Housing, right-hand | 55 5/8 | 1413 | 4 | 102 | 2 1/8 | 54 | 10 | 4.5 |
| VUCHD80 | Housing divider | 55 5/8 | 1413 | 1 1/8 | 29 | 2 | 51 | 3 | 1.4 |
| VUCE46 | Extender | 45 3/4 | 1162 | 4 | 102 | 4 1/4 | 108 | 11 | 5.0 |
| VUCED46 | Extender divider | 45 3/4 | 1162 | 1 1/8 | 29 | 4 | 102 | 3 | 1.4 |

Rev 05/30/18

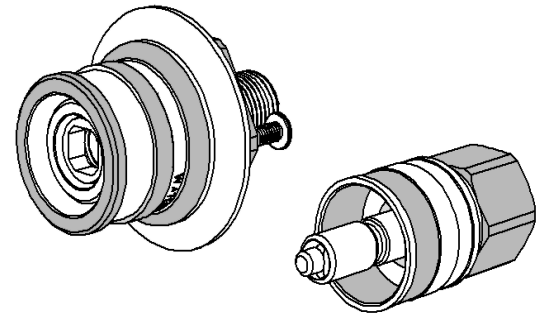
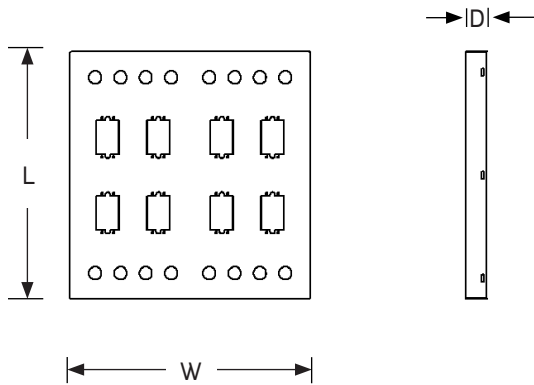

BODY

PLUG

CEILING SERVICE PANEL, QUICK CONNECTS

Ceiling Service Panel

- Ceiling Service Panels are designed to fit in standard 2' x 2' ceiling grid openings.
- Made with 16 gauge sheet metal, ceiling service panels have (16) quick connect knockouts and (8) single electrical and/or data knockouts.

Quick Connect Fittings

- Quick Connect bodies and plugs are finished with polished chrome plated brass.
- Internal quick connect valve components are stainless steel to assure compatibility with the service and to assure durable performance.
- Quick Connect Plugs have an internal shut-off valve that closes when the valve is disengaged.

Cover Plates

- Cover Plates are stainless steel.

How to Specify

Step 1. Product Number

| | |
|----------|----------------------------|
| CSVP2424 | QCD-P- $\frac{3}{8}$ F-ORG |
| CPSHSS | QCD-B- $\frac{3}{8}$ M-ORG |
| CPSBSS | QCS-P- $\frac{3}{8}$ F-YLW |
| CPS3DSS | QCD-B- $\frac{3}{8}$ M-YLW |

Step 2. Paint Color Code (CSVP2424 only)

| | |
|----|---------------|
| AW | Arctic White |
| BK | Black |
| GL | Grey Light |
| NW | Neutral White |

| Product Number | Description | Length | | Width | | Depth | | Weight | |
|----------------------------|--|--------|-------|-------|-------|-------|------|---------------|------|
| | | in. | [mm] | in. | [mm] | in. | [mm] | lb. | [kg] |
| CSVP2424 | Ceiling Service Panel | 23.75 | 10.77 | 23.75 | 10.77 | 2 | 0.90 | 13 | 5.89 |
| QCD-P- $\frac{3}{8}$ F-ORG | Quick connect plug, $\frac{3}{8}$ female | | | | | | | $\frac{1}{2}$ | 0.22 |
| QCD-B- $\frac{3}{8}$ M-ORG | Quick connect body, $\frac{3}{8}$ male | | | | | | | $\frac{1}{2}$ | 0.22 |
| QCS-P- $\frac{3}{8}$ F-YLW | Quick connect plug, $\frac{3}{8}$ female | | | | | | | $\frac{1}{2}$ | 0.22 |
| QCD-B- $\frac{3}{8}$ M-YLW | Quick connect body, $\frac{3}{8}$ male | | | | | | | $\frac{1}{2}$ | 0.22 |
| CPSHSS | Cover plate, single gang, 1.6" dia. hole | | | | | | | $\frac{1}{4}$ | 0.11 |
| CPS3DSS | Cover plate, single gang, 3 data port openings | | | | | | | $\frac{1}{4}$ | 0.11 |
| CPSBSS | Cover plate, single gang, blank | | | | | | | $\frac{1}{4}$ | 0.11 |

Rev 10/29/21



THIS PAGE LEFT BLANK